

 **CIARKO**<sup>®</sup>  
DESIGN



PORTFOLIO



# Viva Polish Design!

We are immensely proud to announce that our **Mono** product family has been awarded the **Gold IF Design Award**, standing out among **11,000** submissions. This year, only **79** projects across all categories were granted the gold awards! This is a tremendous accolade for our work and every Ciarko employee! **Thank you to each and every one of you!**



## Award for Simple, Too!

Among thousands of submissions from around the world, **Simple** stood out with its unique design and innovative technological solutions, gaining jury recognition. This great achievement underscores our commitment to **excellence and the passion** we bring to designing our products. This recognition is also a testament to the **hard work and talent of our team!**



## IF Gold Statement on the Mono Family:

„The **Mono** series of kitchen hoods by **Ciarko Design** exemplifies the balance **between aesthetics** and usability, which is highly sought after but rarely achieved in kitchen design. The icing on the cake is the **touchless gesture control system**, adding a bit of magic to an already intriguing project. **Bravo, Ciarko!**”



This success is not only that of our company but primarily of our **employees and partners** who contribute to our achievements every day. We are proud to celebrate this moment together and look forward to the future with optimism, creating products that combine **beauty, innovation, and functionality.**



## **For 35 years, we have been a market leader, continuously surprising with innovative solutions!**

We proudly design exclusively **in Poland**. We manufacture **3,500** cooker hoods per day, utilizing more than **20,000** square meters of production space. Our annual production exceeds **1,000,000** hoods. All hoods are fully designed and manufactured by our team of over **600** employees.

**Ciarko** is a **family company** not only because of its founder. Throughout the organization, more than **100 families** help create the **Ciarko** brand **every day**, ensuring the unquestionable quality of our products. From the very beginning, the company's mission has been sustainable development and environmental protection.

This year, the company will make an investment in renewable energy that will reduce the consumption of electricity produced during operation, **up to 80%!**

The brand's products have been **appreciated in 48 markets worldwide**, and technologies (among other things, gesture-controlled hood, air ventilation function) allow to improve the quality of time spent in the kitchen for millions of people around the world every year!

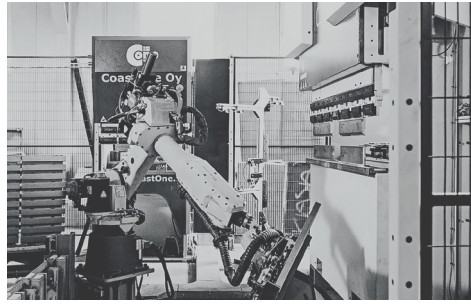

## We always look to the future!

The company's mission is to strengthen Polish technological innovation through cooperation with technological institutes and the Warsaw University of Technology. In 2021, the cooperation of a team of designers of **Ciarko** and scientists resulted in the creation of one of the **quietest BLDC engines** on the market.

**Robotisation rate** of the plant at 112 (the average for Poland is 52) allowed to optimise production processes but at the same time did not lead to the loss of high production flexibility. It has allowed us to combine modern technical and IT solutions with a traditional craftsman's approach, focusing on a love for fine details.

The company also invests in product design and establishes co-working relationships with Polish applied designers, for which it receives numerous awards including the „Oscar” of industrial design **Red Dot Design Award**. Number of projects and collaborations with young designers continues to grow year after year, and their projects are nominated for awards around the world.





*MONO LIGHT / ISLAND MODEL*

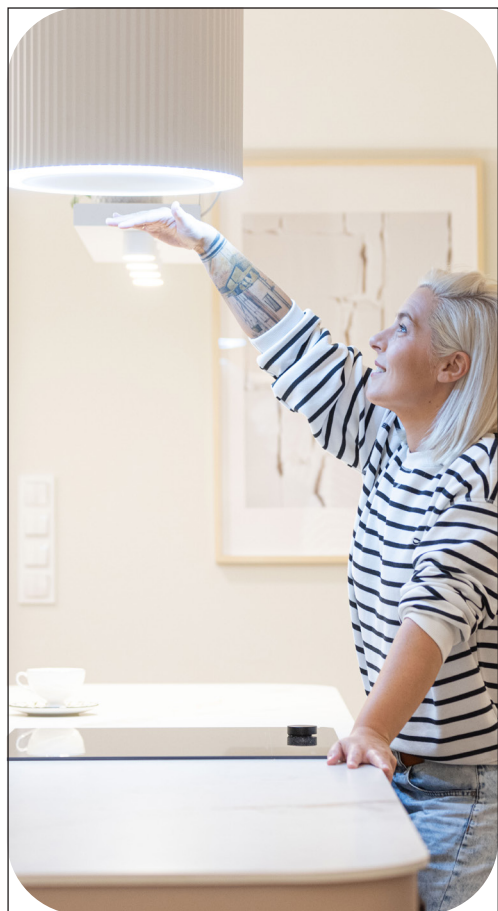

*MONOGRAM W / ISLAND MODEL*



*MONO W / ISLAND MODEL*

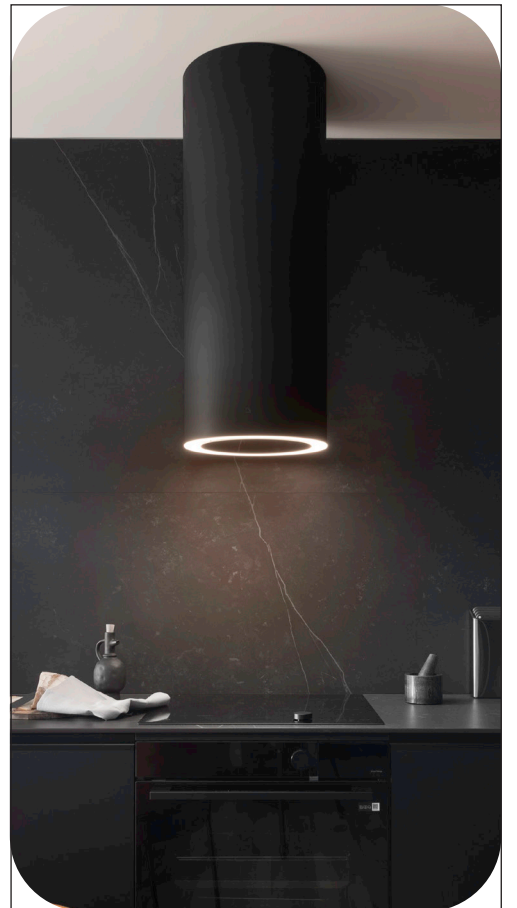

*TUBUS W / ISLAND MODEL*



*ECLIPSE / WALL-MOUNTED MODEL*



*MONOGRAM / WALL-MOUNTED MODEL*





*MONO / WALL-MOUNTED MODEL*



*MOONDRAFT / COUNTERTOP MODEL*



*SU MINI / UNDERCABINET MODEL*



*MINIMAL 7 / UNDERCABINET MODEL*

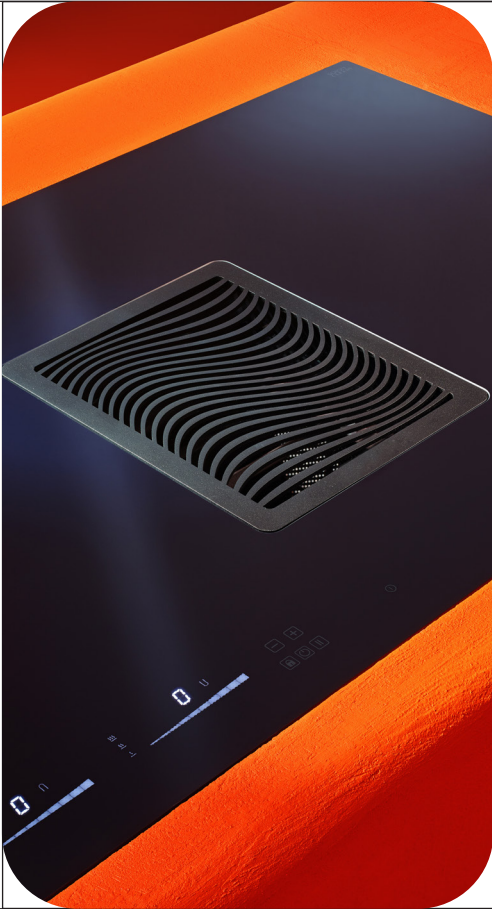

**WIZARD 2.0 / COOKER HOOD INTEGRATED WITH INDUCTION HOB**



**WIZARD ONE / COOKER HOOD INTEGRATED WITH INDUCTION HOB**

That's what makes us special!



*GESTURE CONTROL*  
or remote control.

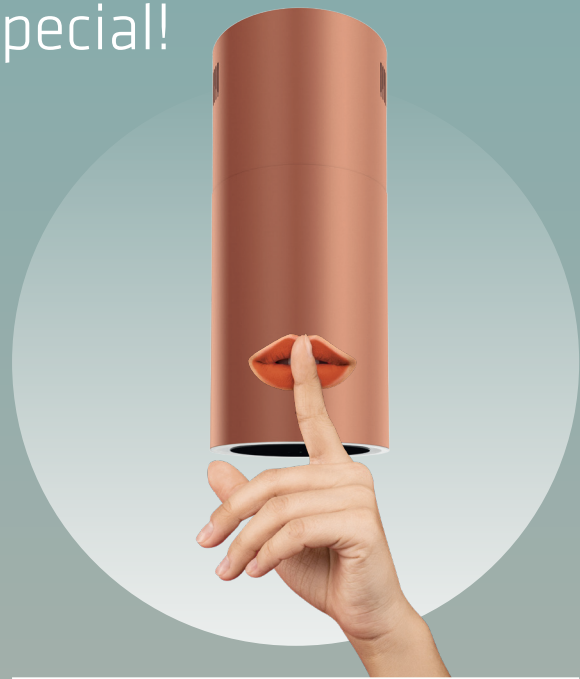

Quiet, brushless and energy-efficient **BLDC** engine.



*Warm2Cold LED* -  
adjustable lighting colour (2900 K - 6000 K).



Perfectly smooth surface resistant to scratches and imprints, **ANTI FINGER PRINT.**

# innovative hood control system



## Gesture Control

Controlling the hood without touching the appliance, exclusively with the movements of our hands, is becoming a reality today. With a **simple gesture**, you can turn the device on or off, or change its settings for power or illumination. It's all thanks to hand motion sensors that make the previously intuitive hardware even more functional.

From now on, its operation does not mean that we have to interrupt an activity just to turn on the hood. To use it, we no longer have to wipe our hands or worry about getting the control panel dirty. Isn't that simplicity at your fingertips?

Keeping the hood clean and controlling its operation has never been easier:

**1**

By holding your hand in front of the hood for about 2 sec, **you will turn on the lighting.**

**2**

Move your hand from left to right **to change the speed mode to a higher one.**

**3**









Shift to a lower gear by moving your hand from right to left and stop for about 2 seconds to **turn off the lights.**



## Mono

WALL MODEL

### A new design!

-  **LED Warm2Cold Lighting** – Adjustable lighting color from warm (2900K) to cool (6000K) and three brightness levels to choose from.
-  **GestureControl** – Hands-free control of the cooker hood's power and lighting using simple hand gestures.
-  **BLDC Motor** – Ensures quiet operation and energy efficiency (8W power consumption).
-  **Anti-Fingerprint Coating** – A smooth, satin-finished surface that resists smudges and fingerprints.
-  **Flexible Installation** – Can be installed as low as 45 cm above an induction cooktop.
-  **Cook Assist** – Automatic synchronization between the cooker hood and the induction cooktop for seamless operation.
-  **Ribbed Surface** – Unique, precision-engineered texture for a distinctive look.
-  **Slot Ventilation** – Air suction technology that pulls air efficiently from across the entire surface of the hood for optimal airflow.
-  **AdaptFlow** – Smart software that optimizes airflow in absorption mode for better performance and efficiency.

COLOURS:

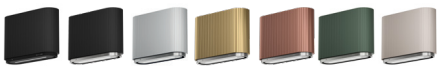

H X W X D:  
492 × 598 × 290 mm  
562 × 799 × 290 mm



NOISE LEVEL:  
40-58 (69) dB  
42-57 (68) dB



PERFORMANCE:  
650 m<sup>3</sup>/h  
730 m<sup>3</sup>/h











FILTERS:  
Long Life M/S  
(OPTIONAL)



## Simple

WALL MODEL

### Form matters!

-  **LED Warm2Cold Lighting** – Adjustable lighting color from warm (2900K) to cool (6000K) and three brightness levels to choose from.
-  **GestureControl** – Hands-free control of the cooker hood's power and lighting using simple hand gestures.
-  **BLDC Motor** – Ensures quiet operation and energy efficiency (8W power consumption).
-  **Anti-Fingerprint Coating** – A smooth, satin-finished surface that resists smudges and fingerprints.
-  **Flexible Installation** – Can be installed as low as 45 cm above an induction cooktop.
-  **Cook Assist** – Automatic synchronization between the cooker hood and the induction cooktop for seamless operation.
-  **Slot Ventilation** – Air suction technology that pulls air efficiently from across the entire surface of the hood for optimal airflow.
-  **AdaptFlow** – Smart software that optimizes airflow in absorption mode for better performance and efficiency.

COLOURS:



H X W X D:  
590 × 598 × 290 mm



NOISE LEVEL:  
40-58 (69) dB



PERFORMANCE:  
650 m<sup>3</sup>/h









FILTERS:  
Long Life M/S  
(OPTIONAL)



## Eclipse

WALL MODEL

### A work of art on your wall!

-  **LED Warm2Cold Lighting** – Adjustable lighting color from warm (2900K) to cool (6000K) and three brightness levels to choose from.
-  **GestureControl** – Hands-free control of the cooker hood's power and lighting using simple hand gestures.
-  **BLDC Motor** – Ensures quiet operation and energy efficiency (8W power consumption).
-  **Flexible Installation** – Can be installed as low as 45 cm above an induction cooktop.
-  **Slot Ventilation** – Air suction technology that pulls air efficiently from across the entire surface of the hood for optimal airflow.
-  **SmartSense Light** – The lighting automatically turns on when you approach the hood.

COLOURS:



H X W X D:  
600 × 600 × 338 mm



NOISE LEVEL:  
44-64 (70) dB



PERFORMANCE:  
735 m<sup>3</sup>/h



FILTERS:  
Long Life E  
(OPTIONAL)



## Illumia

WALL MODEL

**Elegant design and exceptional technical performance**



**LED Warm2Cold Lighting** – Adjustable lighting color from warm (2900K) to cool (6000K) and three brightness levels to choose from.



**GestureControl** – Hands-free control of the cooker hood's power and lighting using simple hand gestures.



**BLDC Motor** – Ensures quiet operation and energy efficiency (8W power consumption).



**Flexible Installation** – Can be installed as low as 45 cm above an induction cooktop.



**Slot Ventilation** – Air suction technology that pulls air efficiently from across the entire surface of the hood for optimal airflow.



**SmartSense Light** – The lighting automatically turns on when you approach the hood.

COLOURS:



H X W X D:  
472-1176 x 898 x 441 mm



NOISE LEVEL:  
43-61 (68) dB



PERFORMANCE:  
730 m3/h



FILTERS:  
2 x FWK 240  
(OPTIONAL)



## Trio

WALL MODEL

**Design that lets you shine**



**LED Warm2Cold Lighting** – Adjustable lighting color from warm (2900K) to cool (6000K) and three brightness levels to choose from.



**GestureControl** – Hands-free control of the cooker hood's power and lighting using simple hand gestures.



**BLDC Motor** – Ensures quiet operation and energy efficiency (8W power consumption).



**Flexible Installation** – Can be installed as low as 45 cm above an induction cooktop.



**Rotating Motor** – Allows for both vertical and horizontal air venting, offering more flexibility in installation.



**AdaptFlow** – Smart software that optimizes airflow in absorption mode for better performance and efficiency.



**SmartSense Light** – The lighting automatically turns on when you approach the hood.

COLOURS:



H X W X D:  
450-1388 x 898 x 403 mm



NOISE LEVEL:  
45-64 (70) dB



PERFORMANCE:  
740 m3/h



FILTERS:  
2x FWN185/V2  
Long Life 280  
(OPTIONAL)



## Minimal 3

WALL MODEL

**All it takes is a small gesture! Find out how easy and convenient the hood control is!**



**LED Warm2Cold Lighting** – Adjustable lighting color from warm (2900K) to cool (6000K) and three brightness levels to choose from.



**GestureControl** – Hands-free control of the cooker hood's power and lighting using simple hand gestures.



**BLDC Motor** – Ensures quiet operation and energy efficiency (8W power consumption).



**Anti-Fingerprint Coating** – A smooth, satin-finished surface that resists smudges and fingerprints.



**Flexible Installation** – Can be installed as low as 45 cm above an induction cooktop.



**Baffle Filter** – Professional-grade filters, commonly used in restaurants, that improve the capture of moisture and grease.



**Rotating Motor** – Allows for both vertical and horizontal air venting, offering more flexibility in installation.

KOLORYSTYKA:



WYS. X SZER. X GŁĘB.  
700-1310 x 400 x 310 mm



GŁOŚNOŚĆ:  
43-58 (69) dB



WYDAJNOŚĆ:  
610 m3/h



FILTR:  
Long Life M3  
(OPCJONALNIE)



| cold, warm, warmer!



## Warm2ColdLED







If you hesitate whether to choose a warm or cool light colour together with Ciarko you can resolve this dilemma once and for all. **Warm2ColdLED** technology gives us the option to adjust the light colour from **2900K** to **6000K**. Warm light, close to sunlight, does not tire the eyes, improving our well-being; while cooler light allows us to expose details and emphasizes the character of the interior. In addition to endless possibilities in kitchen design, **Warm2coldLED** has another advantage: it illuminates the workspace with minimal power consumption. And this is true regardless of the time of day or the weather conditions outside the window.



## Minimal 4

WALL MODEL

**Completely different from all!**

-  **LED Warm2Cold Lighting** – Adjustable lighting color from warm (2900K) to cool (6000K) and three brightness levels to choose from.
-  **GestureControl** – Hands-free control of the cooker hood's power and lighting using simple hand gestures.
-  **BLDC Motor** – Ensures quiet operation and energy efficiency (8W power consumption).
-  **Anti-Fingerprint Coating** – A smooth, satin-finished surface that resists smudges and fingerprints.
-  **Flexible Installation** – Can be installed as low as 45 cm above an induction cooktop.
-  **Baffle Filter** – Professional-grade filters, commonly used in restaurants, that improve the capture of moisture and grease.
-  **Rotating Motor** – Allows for both vertical and horizontal air venting, offering more flexibility in installation.

COLOURS:



H X W X D:  
460-1410 × 599 × 400 mm  
460-1410 × 899 × 400 mm

NOISE LEVEL:  
42-58 (67) dB  
43-59 (69) dB

PERFORMANCE:  
700 m3/h  
715 m3/h







FILTERS:  
2x Long Life M4  
2x Long Life M6  
(OPTIONAL)



## Minimal 5

WALL MODEL

**You deserve functionality in an original setting!**

-  **LED Warm2Cold Lighting** – Adjustable lighting color from warm (2900K) to cool (6000K) and three brightness levels to choose from.
-  **GestureControl** – Hands-free control of the cooker hood's power and lighting using simple hand gestures.
-  **BLDC Motor** – Ensures quiet operation and energy efficiency (8W power consumption).
-  **Anti-Fingerprint Coating** – A smooth, satin-finished surface that resists smudges and fingerprints.
-  **Flexible Installation** – Can be installed as low as 45 cm above an induction cooktop.
-  **Baffle Filter** – Professional-grade filters, commonly used in restaurants, that improve the capture of moisture and grease.
-  **Rotating Motor** – Allows for both vertical and horizontal air venting, offering more flexibility in installation.

COLOURS:



H X W X D:  
460-1410 × 599 × 400 mm  
460-1410 × 899 × 400 mm

NOISE LEVEL:  
42-58 (67) dB  
43-59 (69) dB

PERFORMANCE:  
700 m3/h  
715 m3/h







FILTERS:  
2x Long Life M4  
2x Long Life M6  
(OPTIONAL)



## Minimal 6

WALL MODEL

**All it takes is a small gesture! Find out how easy and convenient the hood control is!**

-  **LED Warm2Cold Lighting** – Adjustable lighting color from warm (2900K) to cool (6000K) and three brightness levels to choose from.
-  **GestureControl** – Hands-free control of the cooker hood's power and lighting using simple hand gestures.
-  **BLDC Motor** – Ensures quiet operation and energy efficiency (8W power consumption).
-  **Anti-Fingerprint Coating** – A smooth, satin-finished surface that resists smudges and fingerprints.
-  **Flexible Installation** – Can be installed as low as 45 cm above an induction cooktop.
-  **Baffle Filter** – Professional-grade filters, commonly used in restaurants, that improve the capture of moisture and grease.
-  **Rotating Motor** – Allows for both vertical and horizontal air venting, offering more flexibility in installation.

COLOURS:



H X W X D:  
460-1410 × 599 × 400 mm  
460-1410 × 899 × 400 mm

NOISE LEVEL:  
42-58 (67) dB  
43-59 (69) dB

PERFORMANCE:  
700 m3/h  
715 m3/h

FILTERS:  
Long Life M6  
2x Long Life M6  
(OPTIONAL)



COLOURS:



H X W X D:  
900 × 382 × 480 mm



NOISE LEVEL:  
39-56 (69) dB



PERFORMANCE:  
670 m<sup>3</sup>/h



FILTERS:  
FWK 228  
Long Life 228  
(OPTIONAL)

## Monogram

WALL MODEL

### Completely different from all!

- LED Warm2Cold Lighting** – Adjustable lighting color from warm (2900K) to cool (6000K) and three brightness levels to choose from.
- GestureControl** – Hands-free control of the cooker hood's power and lighting using simple hand gestures.
- BLDC Motor** – Ensures quiet operation and energy efficiency (8W power consumption).
- Anti-Fingerprint Coating** – A smooth, satin-finished surface that resists smudges and fingerprints.
- Flexible Installation** – Can be installed as low as 45 cm above an induction cooktop.
- Cook Assist** – Automatic synchronization between the cooker hood and the induction cooktop for seamless operation.
- Ribbed Surface** – Unique, precision-engineered texture for a distinctive look.
- Perimeter Lighting** – Decorative LED lighting around the hood's edges with Warm2Cold functionality.
- Slot Ventilation** – Air suction technology that pulls air efficiently from across the entire surface of the hood for optimal airflow.
- AdaptFlow** – Smart software that optimizes airflow in absorption mode for better performance and efficiency.



COLOURS:



H X W X D:  
800 × 382 × 480 mm



NOISE LEVEL:  
39-56 (69) dB



PERFORMANCE:  
670 m<sup>3</sup>/h



FILTERS:  
FWK 228  
Long Life 228  
(OPTIONAL)

## Tubus

WALL MODEL

### The beauty of an unusual form

- LED Warm2Cold Lighting** – Adjustable lighting color from warm (2900K) to cool (6000K) and three brightness levels to choose from.
- GestureControl** – Hands-free control of the cooker hood's power and lighting using simple hand gestures.
- BLDC Motor** – Ensures quiet operation and energy efficiency (8W power consumption).
- Anti-Fingerprint Coating** – A smooth, satin-finished surface that resists smudges and fingerprints.
- Flexible Installation** – Can be installed as low as 45 cm above an induction cooktop.
- Cook Assist** – Automatic synchronization between the cooker hood and the induction cooktop for seamless operation.
- Perimeter Lighting** – Decorative LED lighting around the hood's edges with Warm2Cold functionality.
- Slot Ventilation** – Air suction technology that pulls air efficiently from across the entire surface of the hood for optimal airflow.
- AdaptFlow** – Smart software that optimizes airflow in absorption mode for better performance and efficiency.



COLOURS:



H X W X D:  
900 × 382 × 480 mm



NOISE LEVEL:  
39-56 (69) dB



PERFORMANCE:  
670 m<sup>3</sup>/h



FILTERS:  
FWK 228  
Long Life 228  
(OPTIONAL)

## Roto

WALL MODEL

### A new edition of the grooved surface!

- LED Warm2Cold Lighting** – Adjustable lighting color from warm (2900K) to cool (6000K) and three brightness levels to choose from.
- GestureControl** – Hands-free control of the cooker hood's power and lighting using simple hand gestures.
- BLDC Motor** – Ensures quiet operation and energy efficiency (8W power consumption).
- Anti-Fingerprint Coating** – A smooth, satin-finished surface that resists smudges and fingerprints.
- Flexible Installation** – Can be installed as low as 45 cm above an induction cooktop.
- Cook Assist** – Automatic synchronization between the cooker hood and the induction cooktop for seamless operation.
- Ribbed Surface** – Unique, precision-engineered texture for a distinctive look.
- Perimeter Lighting** – Decorative LED lighting around the hood's edges with Warm2Cold functionality.
- Slot Ventilation** – Air suction technology that pulls air efficiently from across the entire surface of the hood for optimal airflow.
- AdaptFlow** – Smart software that optimizes airflow in absorption mode for better performance and efficiency.



a smart  
connection  
that makes  
cooking easier



### Automatic synchronization

With the **automatic synchronization** of the hood with the induction cooktop, your kitchen becomes **smarter!** The hood will automatically adjust to the intensity of cooking on the induction cooktop, providing the cleanliness and freshness you need.\*







\* Ciarko Design hoods use a wireless communication protocol with induction cooktops that have this functionality. You are not limited to the choice of induction cooktop manufacturer. Choose any cooktop that uses infrared connectivity technology. For confirmation of connectivity, contact the sales department.



## Minimal 8

WALL MODEL

**Functionality backed by performance!**

-  **LED Warm2Cold Lighting** – Adjustable lighting color from warm (2900K) to cool (6000K) and three brightness levels to choose from.
-  **GestureControl** – Hands-free control of the cooker hood's power and lighting using simple hand gestures.
-  **BLDC Motor** – Ensures quiet operation and energy efficiency (8W power consumption).
-  **Anti-Fingerprint Coating** – A smooth, satin-finished surface that resists smudges and fingerprints.
-  **Flexible Installation** – Can be installed as low as 45 cm above an induction cooktop.
-  **Baffle Filter** – Professional-grade filters, commonly used in restaurants, that improve the capture of moisture and grease.

COLOURS:



H X W X D:  
790-1010 x 900 x 500 mm



NOISE LEVEL:  
44-63 (68) dB



PERFORMANCE:  
720 m3/h











FILTERS:  
FWN185/V2  
(OPTIONAL)



## T-light

WALL MODEL

**Simple form and maximum illumination**

-  **LED Warm2Cold Lighting** – Adjustable lighting color from warm (2900K) to cool (6000K) and three brightness levels to choose from.
-  **GestureControl** – Hands-free control of the cooker hood's power and lighting using simple hand gestures.
-  **BLDC Motor** – Ensures quiet operation and energy efficiency (8W power consumption).
-  **Anti-Fingerprint Coating** – A smooth, satin-finished surface that resists smudges and fingerprints.
-  **Flexible Installation** – Can be installed as low as 45 cm above an induction cooktop.
-  **Cook Assist** – Automatic synchronization between the cooker hood and the induction cooktop for seamless operation.
-  **Panel Lighting** – Large light panel that illuminates the entire kitchen workspace.
-  **Slot Ventilation** – Air suction technology that pulls air efficiently from across the entire surface of the hood for optimal airflow.

COLOURS:



H X W X D:  
810-1030 x 599 x 500 mm  
810-1030 x 899 x 500 mm



NOISE LEVEL:  
43-62 (69) dB  
43-62 (69) dB



PERFORMANCE:  
730 m3/h  
740 m3/h











FILTERS:  
FWN185/V2



## Tubus W Long

WALL MODEL

**Created for high rooms**

-  **LED Warm2Cold Lighting** – Adjustable lighting color from warm (2900K) to cool (6000K) and three brightness levels to choose from.
-  **GestureControl** – Hands-free control of the cooker hood's power and lighting using simple hand gestures.
-  **BLDC Motor** – Ensures quiet operation and energy efficiency (8W power consumption).
-  **Anti-Fingerprint Coating** – A smooth, satin-finished surface that resists smudges and fingerprints.
-  **Flexible Installation** – Can be installed as low as 45 cm above an induction cooktop.
-  **Cook Assist** – Automatic synchronization between the cooker hood and the induction cooktop for seamless operation.
-  **Perimeter Lighting** – Decorative LED lighting around the hood's edges with Warm2Cold functionality.
-  **Slot Ventilation** – Air suction technology that pulls air efficiently from across the entire surface of the hood for optimal airflow.
-  **AdaptFlow** – Smart software that optimizes airflow in absorption mode for better performance and efficiency.

COLOURS:



H X W X D:  
1100 - 1475 x 382 x 382 mm



NOISE LEVEL:  
39-56 (69) dB



PERFORMANCE:  
670 m3/h



FILTERS:  
FWK 228  
Long Life 228  
(OPTIONAL)



# Mono Light

ISLAND HOOD

**Functionality, convenience, and beauty in one device!**



**LED Warm2Cold Lighting** - Adjustable lighting color from warm (2900K) to cool (6000K) and three brightness levels to choose from.



**GestureControl** - Hands-free control of the cooker hood's power and lighting using simple hand gestures.



**BLDC Motor** - Ensures quiet operation and energy efficiency (8W power consumption).



**Anti-Fingerprint Coating** - A smooth, satin-finished surface that resists smudges and fingerprints.



**Flexible Installation** - Can be installed as low as 45 cm above an induction cooktop.



**Cook Assist**- Automatic synchronization between the cooker hood and the induction cooktop for seamless operation.



**Ribbed Surface** - Unique, precision-engineered texture for a distinctive look.



**Panel Lighting** - Large light panel that illuminates the entire kitchen workspace.



**Slot Ventilation** - Air suction technology that pulls air efficiently from across the entire surface of the hood for optimal airflow.

COLOURS:



H X W X D:  
650-2830 × 600 × 600 mm  
650-2830 × 800 × 600 mm



NOISE LEVEL:  
43-57 (70) dB  
41-56 (67) dB



PERFORMANCE:  
460 m<sup>3</sup>/h  
640 m<sup>3</sup>/h



FILTERS:  
Long Life M/P  
INCLUDED



# Piu Light

ISLAND HOOD

**Many functions in one device.**



**LED Warm2Cold Lighting** - Adjustable lighting color from warm (2900K) to cool (6000K) and three brightness levels to choose from.



**GestureControl** - Hands-free control of the cooker hood's power and lighting using simple hand gestures.



**BLDC Motor** - Ensures quiet operation and energy efficiency (8W power consumption).



**Anti-Fingerprint Coating** - A smooth, satin-finished surface that resists smudges and fingerprints.



**Flexible Installation** - Can be installed as low as 45 cm above an induction cooktop.



**Cook Assist**- Automatic synchronization between the cooker hood and the induction cooktop for seamless operation.



**Panel Lighting** - Large light panel that illuminates the entire kitchen workspace.



**Slot Ventilation** - Air suction technology that pulls air efficiently from across the entire surface of the hood for optimal airflow.

COLOURS:



H X W X D:  
650-2830 × 600 × 600 mm  
650-2830 × 800 × 600 mm



NOISE LEVEL:  
43-57 (70) dB  
41-56 (67) dB



PERFORMANCE:  
460 m<sup>3</sup>/h  
640 m<sup>3</sup>/h



FILTERS:  
Long Life M/P  
INCLUDED

# I noiseless and **energy-saving**

MANUFACTURED  
IN POLAND

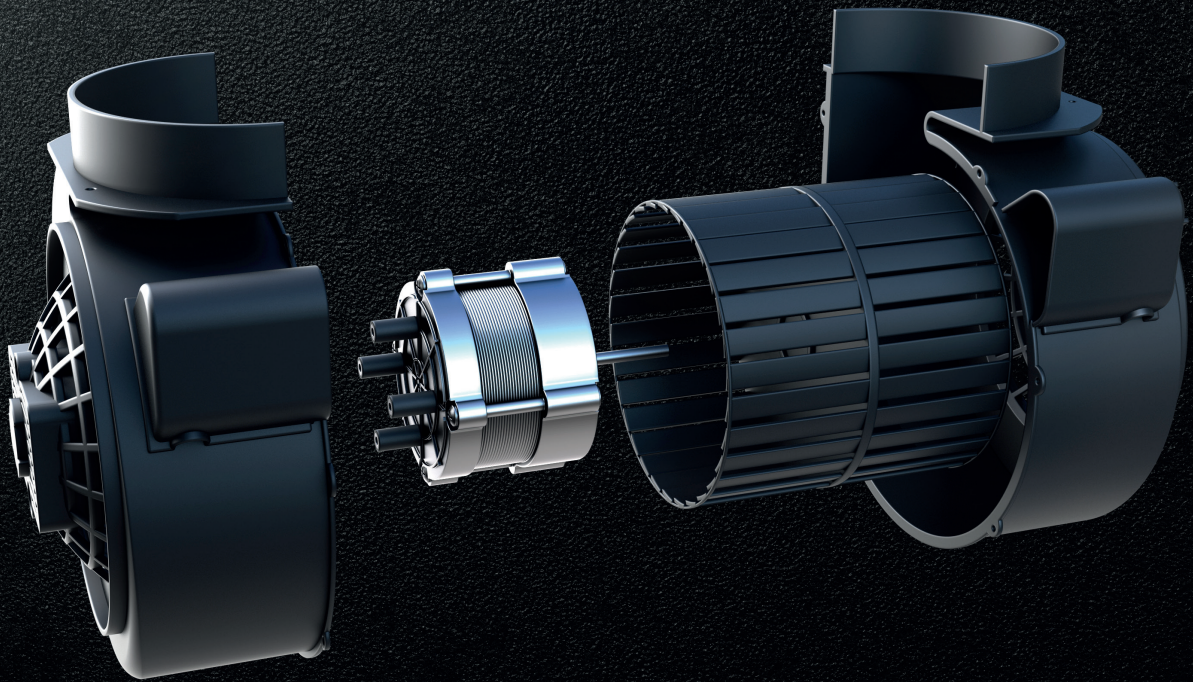

Energy efficiency hidden in the engine i.e.  
**Polish thought has power!**

What do we look for when buying a kitchen hood? Reliable studies show that primarily on the volume and performance of the equipment. Knowing these needs and with many years of experience behind us, we have products to offer, ideally matching the features you are looking for. It was in the Ciarko Design and Minimal hood lines that the high quality offered by the technology developed by Ciarko and the knowledge of engineers from the Warsaw University of Technology who worked on the heart of the hood, i.e. the **BLDC engine**. It is extremely quiet during operation, and also achieves an energy class of **A+++**, which **reduces energy consumption by up to 95%**. Its operation in the first gear, when it needs only **8 W**, can be compared to the energy consumed by a single **small light bulb**. Thanks to the innovative housing, we can reduce the noise level of the hood during operation by as much as **6 dB!** What does this mean in practice? Among other things, the fact that it will not interfere with our conversations, and this is a huge advantage that is becoming our standard. **Ciarko was one of the first brands on the market to lower the volume level of hoods below 40 dB.**



COLOURS:



H X W X D:  
958-1188 x 382 x 382 mm



NOISE LEVEL:  
39-56 (69) dB



PERFORMANCE:  
670 m<sup>3</sup>/h













FILTERS:  
FWK 228  
Long Life 228  
(OPTIONAL)

## Monogram W

ISLAND HOOD

### Completely different from all!

-  **LED Warm2Cold Lighting** - Adjustable lighting color from warm (2900K) to cool (6000K) and three brightness levels to choose from.
-  **GestureControl** - Hands-free control of the cooker hood's power and lighting using simple hand gestures.
-  **BLDC Motor** - Ensures quiet operation and energy efficiency (8W power consumption).
-  **Anti-Fingerprint Coating** - A smooth, satin-finished surface that resists smudges and fingerprints.
-  **Flexible Installation** - Can be installed as low as 45 cm above an induction cooktop.
-  **Cook Assist** - Automatic synchronization between the cooker hood and the induction cooktop for seamless operation.
-  **Ribbed Surface** - Unique, precision-engineered texture for a distinctive look.
-  **Perimeter Lighting** - Decorative LED lighting around the hood's edges with Warm2Cold functionality.
-  **Slot Ventilation** - Air suction technology that pulls air efficiently from across the entire surface of the hood for optimal airflow.
-  **AdaptFlow** - Smart software that optimizes airflow in absorption mode for better performance and efficiency.



COLOURS:



H X W X D:  
958-1188 x 382 x 382 mm



NOISE LEVEL:  
39-56 (69) dB



PERFORMANCE:  
670 m<sup>3</sup>/h













FILTERS:  
FWK 228  
Long Life 228  
(OPTIONAL)

## Roto W

ISLAND HOOD

### Fashionable bends!

-  **LED Warm2Cold Lighting** - Adjustable lighting color from warm (2900K) to cool (6000K) and three brightness levels to choose from.
-  **GestureControl** - Hands-free control of the cooker hood's power and lighting using simple hand gestures.
-  **BLDC Motor** - Ensures quiet operation and energy efficiency (8W power consumption).
-  **Anti-Fingerprint Coating** - A smooth, satin-finished surface that resists smudges and fingerprints.
-  **Flexible Installation** - Can be installed as low as 45 cm above an induction cooktop.
-  **Cook Assist** - Automatic synchronization between the cooker hood and the induction cooktop for seamless operation.
-  **Ribbed Surface** - Unique, precision-engineered texture for a distinctive look.
-  **Perimeter Lighting** - Decorative LED lighting around the hood's edges with Warm2Cold functionality.
-  **Slot Ventilation** - Air suction technology that pulls air efficiently from across the entire surface of the hood for optimal airflow.
-  **AdaptFlow** - Smart software that optimizes airflow in absorption mode for better performance and efficiency.



COLOURS:



H X W X D:  
1025-1200 x 899 x 240 mm



NOISE LEVEL:  
41-61 (69) dB



PERFORMANCE:  
550 m<sup>3</sup>/h











FILTERS:  
Long Life M/W

## Mono W

ISLAND HOOD

### A new design!

-  **LED Warm2Cold Lighting** - Adjustable lighting color from warm (2900K) to cool (6000K) and three brightness levels to choose from.
-  **GestureControl** - Hands-free control of the cooker hood's power and lighting using simple hand gestures.
-  **BLDC Motor** - Ensures quiet operation and energy efficiency (8W power consumption).
-  **Anti-Fingerprint Coating** - A smooth, satin-finished surface that resists smudges and fingerprints.
-  **Flexible Installation** - Can be installed as low as 45 cm above an induction cooktop.
-  **Cook Assist** - Automatic synchronization between the cooker hood and the induction cooktop for seamless operation.
-  **Ribbed Surface** - Unique, precision-engineered texture for a distinctive look.
-  **Slot Ventilation** - Air suction technology that pulls air efficiently from across the entire surface of the hood for optimal airflow.
-  **AdaptFlow** - Smart software that optimizes airflow in absorption mode for better performance and efficiency.





# Minimal 1

ISLAND HOOD

Create a perfectly tailored hood



**LED Warm2Cold Lighting** – Adjustable lighting color from warm (2900K) to cool (6000K) and three brightness levels to choose from.



**GestureControl** – Hands-free control of the cooker hood's power and lighting using simple hand gestures.



**BLDC Motor** – Ensures quiet operation and energy efficiency (8W power consumption).



**Anti-Fingerprint Coating** – A smooth, satin-finished surface that resists smudges and fingerprints.



**Flexible Installation** – Can be installed as low as 45 cm above an induction cooktop.



**Baffle Filter** – Professional-grade filters, commonly used in restaurants, that improve the capture of moisture and grease.



**Decorative Space** – Includes an elegant glass shelf for extra style.



**Hood personalization** – Possibility to add side panels according to your own design.

COLOURS:



H X W X D:  
930-1230 x 900 x 584 mm  
930-1230 x 1200 x 584 mm



NOISE LEVEL:  
38-62 (72) dB



PERFORMANCE:  
550 m3/h



FILTERS:  
Long Life M1  
Long Life M1



# Minimal 2

ISLAND HOOD

Constant attention to detail creates excellence



**LED Warm2Cold Lighting** – Adjustable lighting color from warm (2900K) to cool (6000K) and three brightness levels to choose from.



**GestureControl** – Hands-free control of the cooker hood's power and lighting using simple hand gestures.



**BLDC Motor** – Ensures quiet operation and energy efficiency (8W power consumption).



**Anti-Fingerprint Coating** – A smooth, satin-finished surface that resists smudges and fingerprints.



**Flexible Installation** – Can be installed as low as 45 cm above an induction cooktop.



**Baffle Filter** – Professional-grade filters, commonly used in restaurants, that improve the capture of moisture and grease.



**Decorative Space** – Includes an elegant glass shelf for extra style.



**Customizable Hood** – Add practical hooks for mugs or glasses to personalize your hood.

COLOURS:



H X W X D:  
800-1100 x 1200 x 520 mm  
800-1100 x 1800 x 520 mm



NOISE LEVEL:  
43-59 (69) dB  
43-59 (69) dB



PERFORMANCE:  
675 m3/h



FILTERS:  
FWK280  
FWK300  
Long Life 280  
Long Life 300  
(OPCJONALNIE)



# Miss W

ISLAND HOOD

A striking setting for a modern space



**LED Warm2Cold Lighting** – Adjustable lighting color from warm (2900K) to cool (6000K) and three brightness levels to choose from.



**GestureControl** – Hands-free control of the cooker hood's power and lighting using simple hand gestures.



**BLDC Motor** – Ensures quiet operation and energy efficiency (8W power consumption).



**Anti-Fingerprint Coating** – A smooth, satin-finished surface that resists smudges and fingerprints.



**Flexible Installation** – Can be installed as low as 45 cm above an induction cooktop.



**Cook Assist** – Automatic synchronization between the cooker hood and the induction cooktop for seamless operation.



**Panel Lighting** – Large light panel that illuminates the entire kitchen workspace.



**Slot Ventilation** – Air suction technology that pulls air efficiently from across the entire surface of the hood for optimal airflow.

COLOURS:



H X W X D:  
402-1408 x 502 x 502 mm



NOISE LEVEL:  
41-60 (68) dB



PERFORMANCE:  
475 m3/h











FILTERS:  
FWK 228  
Long Life 228  
(OPCJONALNIE)



# Tubus W

ISLAND HOOD

## Minimalist shape

-  **LED Warm2Cold Lighting** - Adjustable lighting color from warm (2900K) to cool (6000K) and three brightness levels to choose from.
-  **GestureControl** - Hands-free control of the cooker hood's power and lighting using simple hand gestures.
-  **BLDC Motor** - Ensures quiet operation and energy efficiency (8W power consumption).
-  **Anti-Fingerprint Coating** - A smooth, satin-finished surface that resists smudges and fingerprints.
-  **Flexible Installation** - Can be installed as low as 45 cm above an induction cooktop.
-  **Cook Assist** - Automatic synchronization between the cooker hood and the induction cooktop for seamless operation.
-  **Perimeter Lighting** - Decorative LED lighting around the hood's edges with Warm2Cold functionality.
-  **Slot Ventilation** - Air suction technology that pulls air efficiently from across the entire surface of the hood for optimal airflow.
-  **AdaptFlow** - Smart software that optimizes airflow in absorption mode for better performance and efficiency.

COLOURS:



H X W X D:  
958-1188 x 382 x 382 mm



NOISE LEVEL:  
39-56 (69) dB



PERFORMANCE:  
670 m<sup>3</sup>/h











FILTERS:  
FWK 228  
Long Life 228  
(OPCJONALNIE)



# Cube W

ISLAND HOOD

## A hood in designer form!

-  **LED Warm2Cold Lighting** - Adjustable lighting color from warm (2900K) to cool (6000K) and three brightness levels to choose from.
-  **GestureControl** - Hands-free control of the cooker hood's power and lighting using simple hand gestures.
-  **BLDC Motor** - Ensures quiet operation and energy efficiency (8W power consumption).
-  **Anti-Fingerprint Coating** - A smooth, satin-finished surface that resists smudges and fingerprints.
-  **Flexible Installation** - Can be installed as low as 45 cm above an induction cooktop.
-  **Cook Assist** - Automatic synchronization between the cooker hood and the induction cooktop for seamless operation.
-  **Perimeter Lighting** - Decorative LED lighting around the hood's edges with Warm2Cold functionality.
-  **Slot Ventilation** - Air suction technology that pulls air efficiently from across the entire surface of the hood for optimal airflow.
-  **AdaptFlow** - Smart software that optimizes airflow in absorption mode for better performance and efficiency.

COLOURS:



H X W X D:  
975-1205 x 402 x 302 mm



NOISE LEVEL:  
40-57 (69) dB



PERFORMANCE:  
680 m<sup>3</sup>/h



FILTERS:  
FWN 185/V2  
(OPCJONALNIE)



# Su Light

CEILING MODELS

**Minimalism with maximum functionality**



**LED Warm2Cold Lighting** - Adjustable lighting color from warm (2900K) to cool (6000K) and three brightness levels to choose from.



**BLDC Motor** - Ensures quiet operation and energy efficiency (8W power consumption).



**Panel Lighting** - Large light panel that illuminates the entire kitchen workspace.



**Rotating Motor** - Allows for both vertical and horizontal air venting, offering more flexibility in installation.



**Slot Ventilation** - Air suction technology that pulls air efficiently from across the entire surface of the hood for optimal airflow.



**Ceiling Installation** - Can be installed in suspended ceilings with a height of as little as 20 cm.

COLOURS:



H X W X D:  
190 x 900 x 600 mm



NOISE LEVEL:  
44-64 (70) dB



PERFORMANCE:  
750 m3/h



WITHOUT  
FILTER



# Su Frame

CEILING MODELS

**An excellent light source and hood in one**



**LED Warm2Cold Lighting** - Adjustable lighting color from warm (2900K) to cool (6000K) and three brightness levels to choose from.



**BLDC Motor** - Ensures quiet operation and energy efficiency (8W power consumption).



**Perimeter Lighting** - Decorative LED lighting around the hood's edges with Warm2Cold functionality.



**Rotating Motor** - Allows for both vertical and horizontal air venting, offering more flexibility in installation.



**Slot Ventilation** - Air suction technology that pulls air efficiently from across the entire surface of the hood for optimal airflow.



**Ceiling Installation** - Can be installed in suspended ceilings with a height of as little as 20 cm.

COLOURS:



H X W X D:  
190 x 900 x 600 mm



NOISE LEVEL:  
44-64 (70) dB



PERFORMANCE:  
750 m3/h



WITHOUT  
FILTER

safe **discharge**  
**humid air** also **in absorber**  
**mode**

air outlet  
SpaceMax Joker  
- Ciarko Design



## SpaceMax Joker

The original **7 cm** deep air duct intended for the Uno Joker and Duo Joker hoods ensures safe removal of **moist air also in the absorber mode** (thanks to a special Ciarko Design accessory in the SpaceMAX Joker system). **Can be adjusted to any width, height and depth of the cabinet.** Ergonomic and the aesthetic layout of the cabinet (rectangle) means as much as **80% of the space saved** in the cabinet!



# Joker Uno

UNDERCABINET MODELS

**Minimalism with maximum functionality**



**LED Warm2Cold Lighting** - Adjustable lighting color from warm (2900K) to cool (6000K) and three brightness levels to choose from.



**GestureControl** - Hands-free control of the cooker hood's power and lighting using simple hand gestures.



**BLDC Motor** - Ensures quiet operation and energy efficiency (8W power consumption).



**Flexible Installation** - Can be installed as low as 45 cm above an induction cooktop.



**Cook Assist** - Automatic synchronization between the cooker hood and the induction cooktop for seamless operation.



**Perimeter Lighting** - Decorative LED lighting around the hood's edges with Warm2Cold functionality.



**AdaptFlow** - Smart software that optimizes airflow in absorption mode for better performance and efficiency.



**System SpaceMax Joker** - Innovative solution that increases storage space in upper kitchen cabinets by up to 80%.

COLOURS:



A+  
A+



H X W X D:  
241 x 550 x 290 mm  
241 x 740 x 290 mm



NOISE LEVEL:  
38-55 (68) dB  
38-55 (68) dB



PERFORMANCE:  
650 m3/h  
660 m3/h



FILTERS:

**FWK385**  
Long Life 385

**FWK 485**  
Long Life 485  
(OPTIONAL)



# Joker Duo

UNDERCABINET MODELS

**An excellent light source and hood in one**



**LED Warm2Cold Lighting** - Adjustable lighting color from warm (2900K) to cool (6000K) and three brightness levels to choose from.



**GestureControl** - Hands-free control of the cooker hood's power and lighting using simple hand gestures.



**BLDC Motor** - Ensures quiet operation and energy efficiency (8W power consumption).



**Flexible Installation** - Can be installed as low as 45 cm above an induction cooktop.



**Cook Assist** - Automatic synchronization between the cooker hood and the induction cooktop for seamless operation.



**Perimeter Lighting** - Decorative LED lighting around the hood's edges with Warm2Cold functionality.



**AdaptFlow** - Smart software that optimizes airflow in absorption mode for better performance and efficiency.



**System SpaceMax Joker** - Innovative solution that increases storage space in upper kitchen cabinets by up to 80%.

COLOURS:



A  
A



H X W X D:  
241 x 550 x 290 mm  
241 x 740 x 290 mm



NOISE LEVEL:  
38-55 (68) dB  
38-55 (68) dB



PERFORMANCE:  
650 m3/h  
660 m3/h



FILTERS:

**FWK385**  
Long Life 385

**FWK 485**  
Long Life 485  
(OPTIONAL)



# Uno

UNDERCABINET MODELS

## Minimalism with maximum functionality



**LED Warm2Cold Lighting** - Adjustable lighting color from warm (2900K) to cool (6000K) and three brightness levels to choose from.



**GestureControl** - Hands-free control of the cooker hood's power and lighting using simple hand gestures.



**BLDC Motor** - Ensures quiet operation and energy efficiency (8W power consumption).



**Flexible Installation** - Can be installed as low as 45 cm above an induction cooktop.



**Cook Assist** - Automatic synchronization between the cooker hood and the induction cooktop for seamless operation.



**Slot Ventilation** - Air suction technology that pulls air efficiently from across the entire surface of the hood for optimal airflow.



**AdaptFlow** - Smart software that optimizes airflow in absorption mode for better performance and efficiency.

COLOURS:



A++



H X W X D:  
265 x 551 x 290 mm  
265 x 740 x 290 mm



NOISE LEVEL:  
39-57 (68) dB  
40-58 (68) dB



PERFORMANCE:  
705 m3/h  
740 m3/h



FILTERS:  
FWK385  
Long Life 385  
FWK485  
Long Life 485  
(OPTIONAL)



# Duo

UNDERCABINET MODELS

## An excellent light source and hood in one



**LED Warm2Cold Lighting** - Adjustable lighting color from warm (2900K) to cool (6000K) and three brightness levels to choose from.



**GestureControl** - Hands-free control of the cooker hood's power and lighting using simple hand gestures.



**BLDC Motor** - Ensures quiet operation and energy efficiency (8W power consumption).



**Flexible Installation** - Can be installed as low as 45 cm above an induction cooktop.



**Cook Assist** - Automatic synchronization between the cooker hood and the induction cooktop for seamless operation.



**Slot Ventilation** - Air suction technology that pulls air efficiently from across the entire surface of the hood for optimal airflow.



**AdaptFlow** - Smart software that optimizes airflow in absorption mode for better performance and efficiency.

COLOURS:



A++



H X W X D:  
265 x 551 x 290 mm  
265 x 740 x 290 mm



NOISE LEVEL:  
39-57 (68) dB  
40-58 (68) dB



PERFORMANCE:  
710 m3/h  
740 m3/h



FILTERS:  
FWK385  
Long Life 385  
FWK485  
Long Life 485  
(OPTIONAL)



COLOURS:



## Su Mini

UNDERCABINET MODELS

### The perfect hood in a built-in kitchen



**LED Warm2Cold Lighting** - Adjustable lighting color from warm (2900K) to cool (6000K) and three brightness levels to choose from.



**GestureControl** - Hands-free control of the cooker hood's power and lighting using simple hand gestures.



**BLDC Motor** - Ensures quiet operation and energy efficiency (8W power consumption).



**Flexible Installation** - Can be installed as low as 45 cm above an induction cooktop.



**Cook Assist** - Automatic synchronization between the cooker hood and the induction cooktop for seamless operation.



**Panel Lighting** - Large light panel that illuminates the entire kitchen workspace.



**Rotating Motor** - Allows for both vertical and horizontal air venting, offering more flexibility in installation.



**Slot Ventilation** - Air suction technology that pulls air efficiently from across the entire surface of the hood for optimal airflow.



**AdaptFlow** - Smart software that optimizes airflow in absorption mode for better performance and efficiency.



H X W X D:  
320 x 600 x 310 mm  
320 x 740 x 290 mm



NOISE LEVEL:  
42-58 (68) dB  
42-58 (69) dB



PERFORMANCE:  
680 m3/h  
690 m3/h



FILTERS:  
FWN 185/V2  
Long Life 467  
Long Life 485  
(OPTIONAL)



COLOURS:



## Aura

UNDERCABINET MODELS

### Maximum glass surface



**LED Warm2Cold Lighting** - Adjustable lighting color from warm (2900K) to cool (6000K) and three brightness levels to choose from.



**GestureControl** - Hands-free control of the cooker hood's power and lighting using simple hand gestures.



**BLDC Motor** - Ensures quiet operation and energy efficiency (8W power consumption).



**Flexible Installation** - Can be installed as low as 45 cm above an induction cooktop.



**Cook Assist** - Automatic synchronization between the cooker hood and the induction cooktop for seamless operation.



**Rotating Motor** - Allows for both vertical and horizontal air venting, offering more flexibility in installation.



**Slot Ventilation** - Air suction technology that pulls air efficiently from across the entire surface of the hood for optimal airflow.



**AdaptFlow** - Smart software that optimizes airflow in absorption mode for better performance and efficiency.

A++



H X W X D:  
280 x 550 x 290 mm  
280 x 740 x 290 mm



NOISE LEVEL:  
42-58 (69) dB  
42-58 (69) dB



PERFORMANCE:  
680 m3/h  
690 m3/h



FILTERS:  
FWN 385  
FWK 485  
Long Life 385  
Long Life 485  
(OPTIONAL)



COLOURS:



## Minimal 7

UNDERCABINET MODELS

### A hood created with your needs in mind!



**LED Warm2Cold Lighting** - Adjustable lighting color from warm (2900K) to cool (6000K) and three brightness levels to choose from.



**GestureControl** - Hands-free control of the cooker hood's power and lighting using simple hand gestures.



**BLDC Motor** - Ensures quiet operation and energy efficiency (8W power consumption).



**Flexible Installation** - Can be installed as low as 45 cm above an induction cooktop.



**Baffle Filter** - Professional-grade filters, commonly used in restaurants, that improve the capture of moisture and grease.



**Rotating Motor** - Allows for both vertical and horizontal air venting, offering more flexibility in installation.



**AdaptFlow** - Smart software that optimizes airflow in absorption mode for better performance and efficiency.



H X W X D:  
320 x 550 x 290 mm  
320 x 740 x 290 mm  
320 x 900 x 290 mm



NOISE LEVEL:  
43-59 (69) dB  
43-59 (69) dB  
43-59 (69) dB



PERFORMANCE:  
650 m3/h  
660 m3/h  
670 m3/h



FILTERS:  
FWN185/V2  
FWN185/V2  
FWN185/V2  
(OPTIONAL)

# safe removal of humid air, in recirculation mode



## SpaceMax Wizard

Safe removal of humid air, in recirculation mode. Very easy and quick installation – no need to install and connect ventilation ducts.

**With the SpaceMax Wizard system, you save space in your cabinet,** allowing for full-depth drawers to be installed.

The SpaceMax Wizard system also **protects the cabinet from moisture.**

It is made entirely of stainless steel, making it highly hygienic.

traditional  
air outlet

495mm

SpaceMax Wizard air  
outlet - Ciarko Design

35mm

680mm - 810mm

560mm

565mm







FRAME COLOURS:



POWER:  
7560 W

A+\*

H X W X D:  
233 x 830 x 515 mm

NOISE LEVEL:  
36-61 (68) dB

PERFORMANCE:  
730 m3/h

FILTER INCLUDED

# Wizard 2.0

MODEL INTEGRATED WITH INDUCTION HOB

## Hood and induction cooktop in one appliance!



**Drip Control** - An innovative system designed for easy collection and removal of spilled liquids.



**Automatic hood operation** - The range hood's power, on/off, and extraction strength are controlled automatically. You can switch to manual mode at any time.



**Two Bridge Zones** - The induction cooktop is equipped with a function that splits and combines cooking zones, allowing for even heating of large or irregularly shaped pots.



**Boost** - This function allows you to increase the power to maximum with a single button, reducing cooking time to a minimum.



**Cooking Programs** - Choose from three temperature levels: 44°C, 70°C, and 94°C. Quickly and conveniently adjust the temperature to suit the dish you're preparing.



**Timer** - Set the cooking time for each cooking zone individually.



**Pan Detection** - The system automatically detects the pan and allows the heating zones to be activated.



**Odor-Free** - The metal construction and stainless steel chamber of the range hood do not retain odors.



**Customize to your needs** - You decide whether the air outlet is installed at the front or back of the cabinet. The Wizard hood is available both as an extractor or a recirculator with carbon filters.



**SpaceMax Wizard** - Compatible with the special SpaceMax Wizard air duct.



**Flush installation with the countertop** - The cooktop can be fully integrated into the countertop.



**Heating zone size:** 4x 220 x 185 mm.

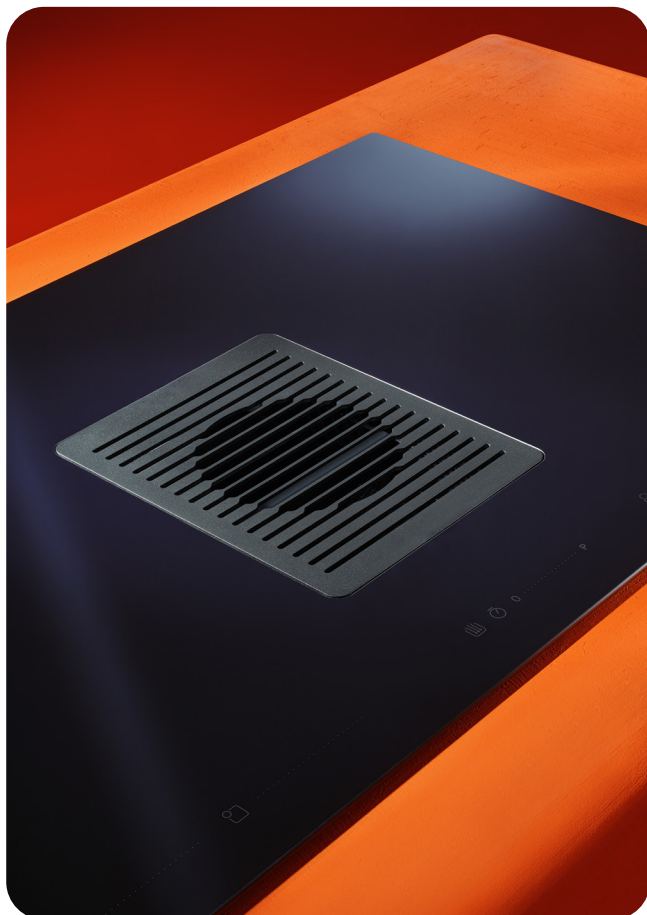

FRAME COLOURS:

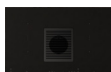

POWER:  
7560 W

A+\*

H X W X D:  
232 x 830 x 515 mm

NOISE LEVEL:  
38-59 (68) dB

PERFORMANCE:  
655 m3/h

FILTER INCLUDED

# Wizard One

MODEL INTEGRATED WITH INDUCTION HOB

## So effective that you will see it!



**Drip Control** - An innovative system designed for easy collection and removal of spilled liquids.



**Automatic hood operation** - The range hood's power, on/off, and extraction strength are controlled automatically. You can switch to manual mode at any time.



**Two Bridge Zones** - The induction cooktop is equipped with a function that splits and combines cooking zones, allowing for even heating of large or irregularly shaped pots.



**Boost** - This function allows you to increase the power to maximum with a single button, reducing cooking time to a minimum.



**Timer** - Set the cooking time for each cooking zone individually.



**Pan Detection** - The system automatically detects the pan and allows the heating zones to be activated.



**Odor-Free** - The metal construction and stainless steel chamber of the range hood do not retain odors.



**Customize to your needs** - You decide whether the air outlet is installed at the front or back of the cabinet. The Wizard hood is available both as an extractor or a recirculator with carbon filters.



**SpaceMax Wizard** - Compatible with the special SpaceMax Wizard air duct.



**Flush installation with the countertop** - The cooktop can be fully integrated into the countertop.



**Heating zone size:** 4x 185 x 185 mm.

# Wizard Slim

MODEL INTEGRATED WITH INDUCTION HOB

## Maximum power, minimum space!



**Compact Induction Solution** - Now you can enjoy all the advantages of our induction cooktop, even in more compact kitchens and 60cm cabinets. It's the ideal solution for kitchens with limited space.



**Automatic hood operation** - The range hood's power, on/off, and extraction strength are controlled automatically. You can switch to manual mode at any time.



**Two Bridge Zones** - The induction cooktop is equipped with a function that splits and combines cooking zones, allowing for even heating of large or irregularly shaped pots.



**Boost** - This function allows you to increase the power to maximum with a single button, reducing cooking time to a minimum.



**Cooking Programs** - Quickly and conveniently adjust the temperature to suit.



**Odor-Free** - The metal construction and stainless steel chamber of the range hood do not retain odors.



**Customize to your needs** - You decide whether the air outlet is installed at the front or back of the cabinet. The Wizard hood is available both as an extractor or a recirculator with carbon filters.



**SpaceMax Wizard** - Compatible with the special SpaceMax Wizard air duct.



**Flush installation with the countertop** - The cooktop can be fully integrated into the countertop.



**Heating zone size:** 4x ø 180 mm.

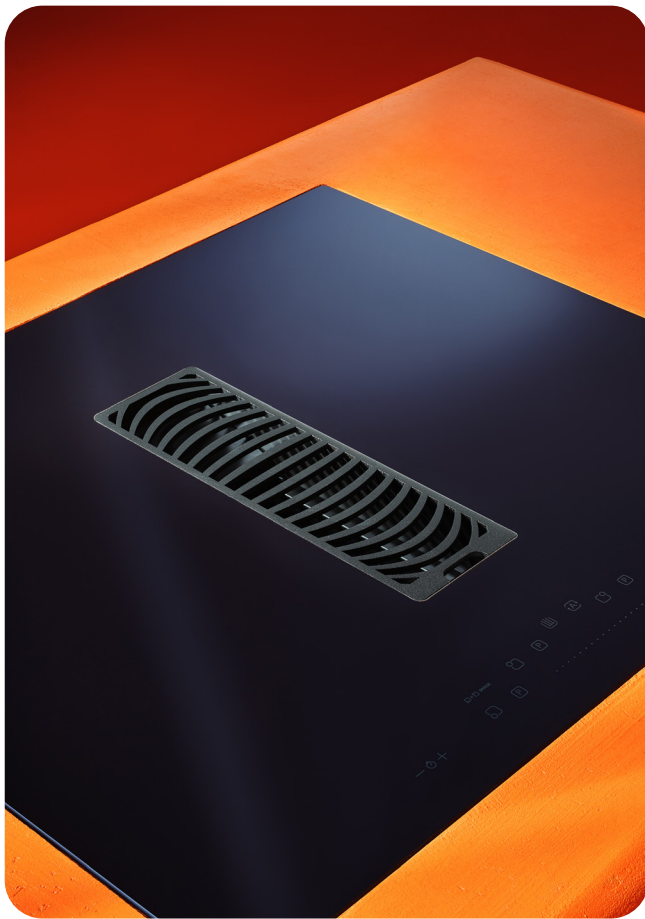

FRAME COLOURS:



FILTER INCLUDED



POWER:  
**7360 W**



H X W X D:

**241 x 600/720 x 515 mm**



NOISE LEVEL:  
**36-59 (69) dB**



PERFORMANCE:  
**550 m3/h**



# Moondraft

COUNTERTOP MODELS

## A new dimension of minimalism



**BLDC Motor** - Ensures quiet operation (from 38 dB) and energy efficiency (8W power consumption).



**Optional Motor Kit** - The optional motor kit allows you to conveniently reposition the motor up to 8 meters away to a location of your choice.



**50 cm extendable Hood** - Extends up to 50 cm, making it easier to use with large pots and pans.



**Mounting flush with the countertop** - Moondraft cooker hood can be mounted flush with the countertop. flush with the countertop, which protects the glass from possible damage and helps maintain cleanliness.



**Timer** - on each field allows you to precisely control the cooking time, making meal preparation much easier.



H X W X D:

**724-500 x 600 x 333 mm**  
**724-500 x 898 x 374 mm**



NOISE LEVEL:  
**51-65 (69) dB**  
**52-65 (67) dB**



PERFORMANCE:  
**670 m3/h**  
**730 m3/h**



FILTERS:

**FWK 280**  
**Long Life 150**  
**Long Life 280**  
(OPCJONALNIE)



## CulinaSync Advanced

INDUCTION HOB

**When elegance meets functionality!**

H X W X D:  
65 × 600 × 515 mm

POWER:  
7200 W



**Mounting flush with the countertop** You can completely flush the plate with the countertop.



**Slider** Get full control of your cooktop with a convenient slider that lets you easily adjust the cooking fields. It's the way to cook at the touch of a finger.



**Cook Assist** provides a wireless connection between the hob and the hood. Simply start cooking and the hood will automatically adjust its settings based on the options you select on the hob. Concentrate only on cooking.



A dedicated **Timer** on each field allows you to precisely control the cooking time, making meal preparation much easier.



**Bridge** in an induction cooktop allows you to combine two heating fields into one large cooking surface. With automatic synchronization of temperature and time settings, it is ideal for using grill plates and bakeware.



Activate **Boost** to increase the heating power. This is the ideal solution to cook food even faster.

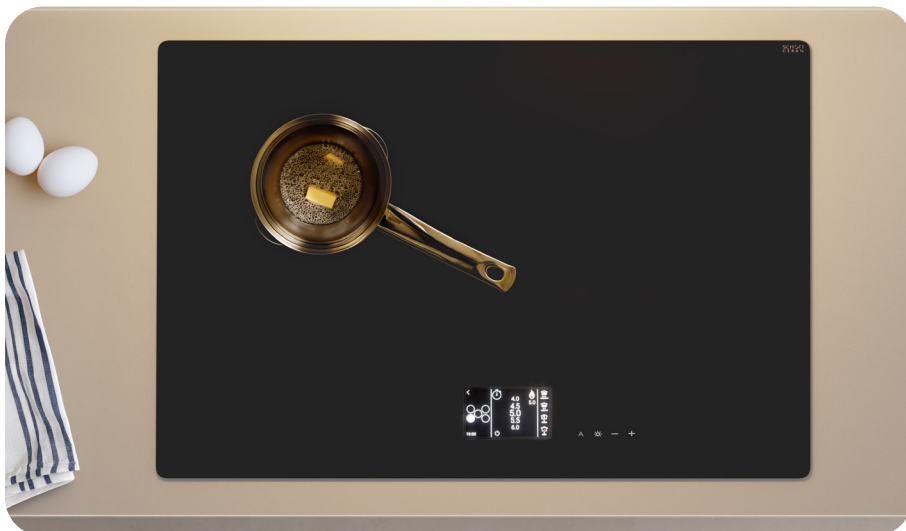

## CulinaSync Ultimate

INDUCTION HOB

**Technology that is changing Cooking!**

H X W X D:  
56 × 775 × 520 mm

POWER:  
7200 W



**A 5-field plate** means even more room for new culinary ideas. Let nothing limit your culinary enthusiasm anymore!



**Mounting flush with the countertop** You can completely flush the plate with the countertop.



**Automatic cooking programs.** The hob has 3 automatic functions: defrost, keep warm and reheat function.



**Touchscreen display.** Get full control over your cooktop with the color touchscreen display. It provides real-time information about the operation of the cooking fields and allows you to adjust their settings accordingly.



**Cook Assist** provides a wireless connection between the hob and the hood. Simply start cooking and the hood will automatically adjust its settings based on the options you select on the hob. Concentrate only on cooking.



A dedicated **Timer** on each field allows you to precisely control the cooking time, making meal preparation much easier.



**Bridge** in an induction cooktop allows you to combine two heating fields into one large cooking surface. With automatic synchronization of temperature and time settings, it is ideal for using grill plates and bakeware.



Activate **Boost** to increase the heating power. This is the ideal solution to cook food even faster.

## ACCESSORIES / CARBON FILTERS

HERE YOU WILL FIND FILTERS, DUCTS AND OTHER ACCESSORIES NEEDED FOR THE PROPER INSTALLATION AND OPERATION OF THE KITCHEN HOOD.

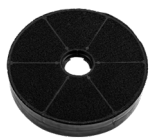

**Filter  
FWK 185**

FOR HOODS: **CUBE, MINIMAL 7, MINIMAL 8, SU MINI 60**

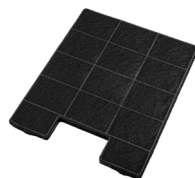

**Filter  
FWK 300**

FOR HOODS: **MINIMAL 2 180CM**



**Filter  
FWK 228**

FOR HOODS: **MISS W, MONOGRAM, MONOGRAM W, ROTO, ROTO W, TUBUS, TUBUS W**

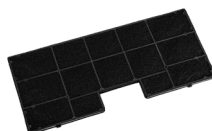

**Filter  
FWK 385**

FOR HOODS: **AURA 55CM, DUO 55CM, JOKER DUO 55CM, JOKER UNO 55CM, UNO 55CM**

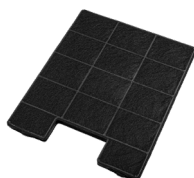

**Filter  
FWK 240**

FOR HOOD: **ILLUMIA**

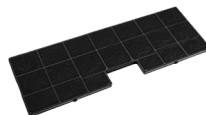

**Filter  
FWK 485**

FOR HOODS: **AURA 74CM, DUO 74CM, JOKER DUO 74CM, JOKER UNO 74CM, SU MINI 74CM, UNO 74CM**

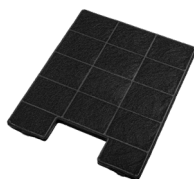

**Filter  
FWK 280**

FOR HOODS: **MINIMAL 2 120 CM, MOONDRAFT 90, TRIO**

## ACCESSORIES / FILTER LONG LIFE

EQUIPPED WITH ACTIVATED CARBON, THEY HAVE A STRUCTURE WITH A HIGHER ACTIVE CARBON CONTENT THAN STANDARD FILTERS. THEIR SERVICE LIFE REACHES 2.5-3 YEARS, REQUIRING REGENERATION EVERY 4-6 MONTHS, WHICH CAN BE DONE BY WASHING THEM IN THE DISHWASHER.

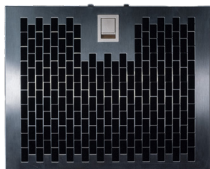

**Filter  
Long Life M1**

FOR HOOD: **MINIMAL 1 / 90, MINIMAL 1 / 120**



**Filter  
Long Life M/S**

FOR HOOD: **MONO 60 / MONO 80 / SIMPLE**

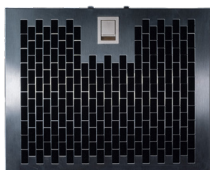

**Filter  
Long Life M3**

FOR HOOD: **MINIMAL 3**



**Filter  
Long Life 228**

FOR HOODS: **MISS W, MONOGRAM, MONOGRAM W, ROTO, ROTO W, TUBUS, TUBUS W**



**Filter  
Long Life M4**

FOR HOODS: **MINIMAL 4 60CM, MINIMAL 5 60CM**



**Filter  
Long Life 385**

FOR HOODS: **AURA 55 CM, DUO 55 CM, JOKER DUO 55 CM, JOKER UNO 55 CM, UNO 55 CM**

## ACCESSORIES / FILTER LONG LIFE

HERE YOU WILL FIND FILTERS, DUCTS AND OTHER ACCESSORIES NEEDED FOR THE PROPER INSTALLATION AND OPERATION OF THE KITCHEN HOOD.

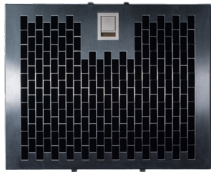

**Filter  
Long Life M6**

FOR HOODS: **MINIMAL 6 90 CM, MINIMAL 4 90 CM,  
MINIMAL 5 90 CM, MINIMAL 6 60 CM**

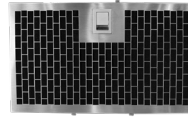

**Filter  
Long Life M/P**

FOR HOODS: **MONO LIGHT, PIU LIGHT**



**Filter  
Long Life E**

FOR HOOD: **ECLIPSE**

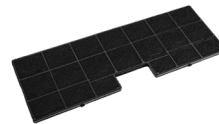

**Filter  
Long Life 485**

FOR HOODS: **AURA 74 CM, DUO 74 CM, JOKER DUO  
74 CM, JOKER UNO 74 CM, SU MINI 74 CM,  
UNO 74 CM**



**Filter  
Long Life 150**

FOR HOOD: **MOONDRAFT 60 CM**



**Filter  
Long Life M/W**

FOR HOOD: **MONO W**

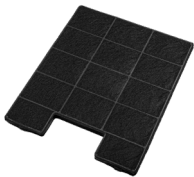

**Filter  
Long Life 280**

FOR HOODS: **MINIMAL 2 120 CM, MOONDRAFT 90  
CM, TRIO**



**Grease filter  
Long Life Wizard 2.0  
+ filter holder  
(set)**

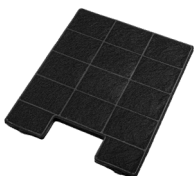

**Filter  
Long Life 300**

FOR HOODS: **MINIMAL 2 180 CM, T-LIGHT 60 CM,  
T-LIGHT 90 CM**

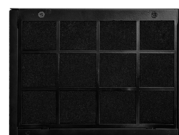

**Grease filter  
Long Life Wizard One - 2 pieces  
+ filter holder  
(set)**

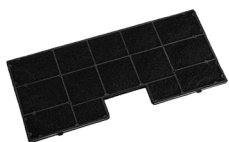

**Filter  
Long Life 467**

FOR HOOD: **SU MINI 60 CM**



**Grease filter  
Long Life Wizard Slim - 2 pieces  
+ filter holder  
(set)**

## ACCESSORIES / SPACE MAX WIZARD AND MAX SPACE JOKER



**SpaceMax Wizard**

FOR: **WIZARD 2.0, WIZARD ONE,  
WIZARD SLIM.**



**SpaceMax Joker  
white/black**

FOR HOODS: **UNO JOKER, DUO JOKER**

# ACCESSORIES

THE HIGHEST QUALITY DUCTS, ASSEMBLED USING FLEXIBLE CONNECTORS WITH INTEGRATED SEALS, ENSURING TIGHTNESS IN ACCORDANCE WITH HIGH ATC3 CLASS STANDARDS AND WITH A SYSTEM ENABLING SMOOTH ANGLE ADJUSTMENT IN THE RANGE OF 0-15 DEGREES.

 <p><b>Round channel</b>  <math>\varnothing</math> 150 mm,          L= 1000 mm</p>	 <p><b>Short channel connector</b>          round <math>\varnothing</math> 150 mm          with a flat channel          222x89mm</p>
 <p><b>Flat channel</b>          222x89 mm,          L=1000 mm</p>	 <p><b>Channel connector</b>          round <math>\varnothing</math> 150 mm          with a flat channel          222x89mm</p>
 <p><b>Knee flat</b>          horizontal 90°          222x89mm</p>	 <p><b>Flexible connector</b>          (up to 15°) flat ducts          222x89 mm</p>
 <p><b>Knee flat</b>          horizontal 30° 222x89 mm</p>	 <p><b>Flexible connector</b>          (up to 15°) round ducts <math>\varnothing</math>          150 mm</p>
 <p><b>90° round elbow</b>  <math>\varnothing</math> 150 mm</p>	 <p><b>Universal channel</b>          cable L= 900 mm</p>
 <p><b>Knee flat</b>          vertical short 90° 222x89          mm          (dedicated to shallow cabinets)</p>	 <p><b>Flexible handle</b>          to the round channel  <math>\varnothing</math> 150 mm</p>
 <p><b>Knee flat</b>          vertical 90°          222x89mm</p>	 <p><b>Wall channel</b>          with the Thermobox system          entrance <math>\varnothing</math> 150 mm,          round grille,          stainless steel</p>
 <p><b>Round knee</b>          90° connectors  <math>\varnothing</math> 150 mm to flat 222x89          mm</p>	 <p><b>Wall channel</b>          with the Thermobox system          entrance <math>\varnothing</math> 150 mm,          rectangular grille,          stainless steel</p>

# ACCESSORIES

HERE YOU WILL FIND FILTERS, DUCTS AND OTHER ACCESSORIES NEEDED FOR THE PROPER INSTALLATION AND OPERATION OF THE KITCHEN HOOD.

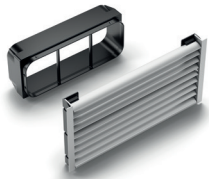

**Grille ventilation stainless steel 297x150 mm**



**Canal flexible 222x89 mm, L = 250-550 mm**

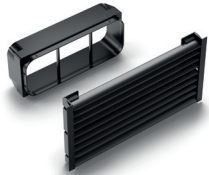

**Grille ventilation black matt 297x150 mm**



**Assembly kit engine outside for Moondraft hood**



**Assembly kit engine outside for hoods: Su Frame and SuLight**

# DECORATIVE ACCESSORIES



**Decorative frame Wizard 2.0 #1**

AVAILABLE COLORS: ● ● ●

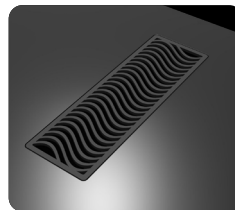

**Decorative frame Wizard Slim #1**

AVAILABLE COLORS: ● ● ●



**Decorative frame Wizard 2.0 #2**

AVAILABLE COLORS: ● ● ●



**Decorative frame Wizard Slim #2**

AVAILABLE COLORS: ● ● ●

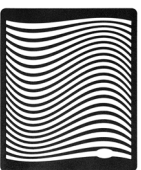

**Decorative frame Wizard 2.0 #3**

AVAILABLE COLORS: ● ● ●



**Decorative frame Wizard Slim #3**

AVAILABLE COLORS: ● ● ●



**Decorative frame Wizard One**

AVAILABLE COLORS: ●

# TECHNICAL DRAWINGS

## ISLAND HOODS

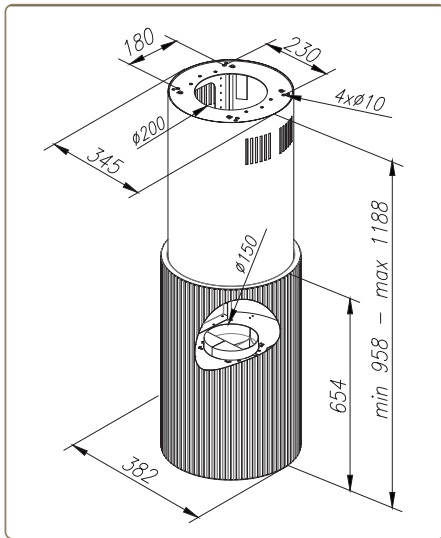

**MONOGRAM W**

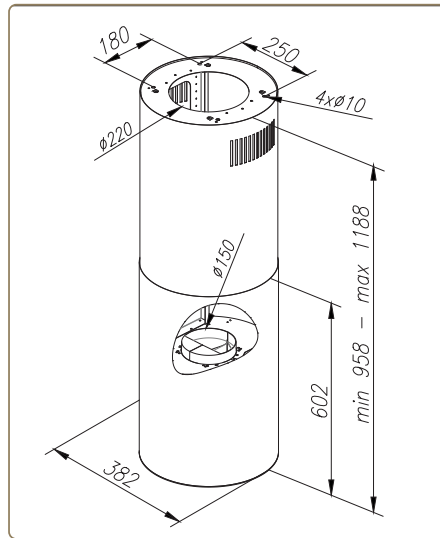

**TUBUS W**

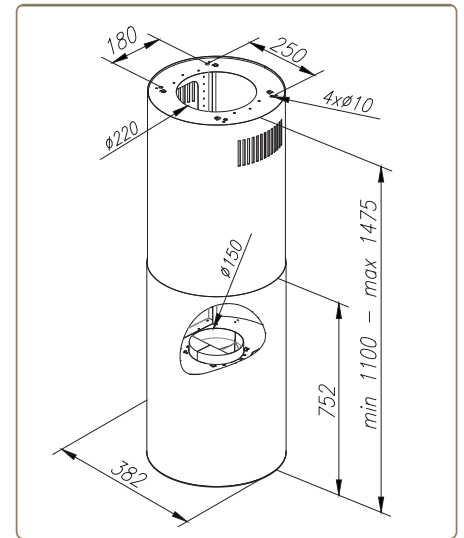

**TUBUS W LONG**

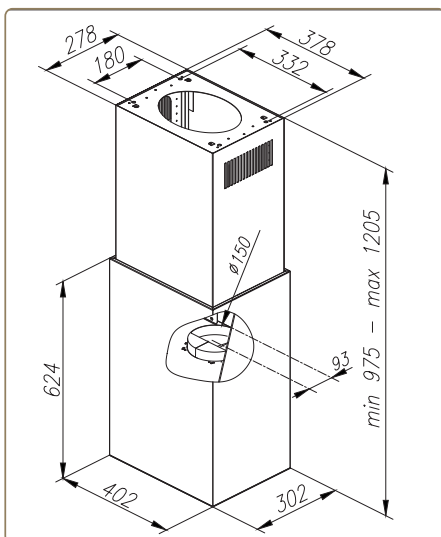

**CUBE W**

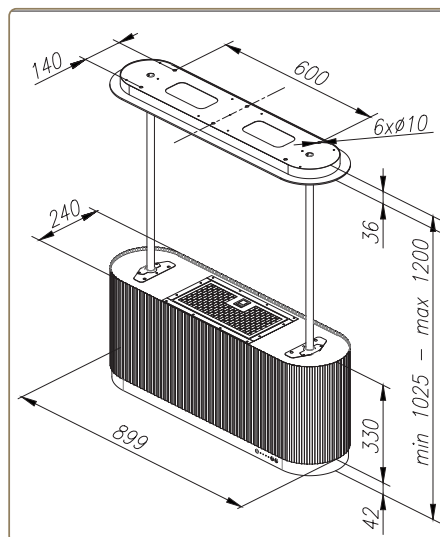

**MONO W**

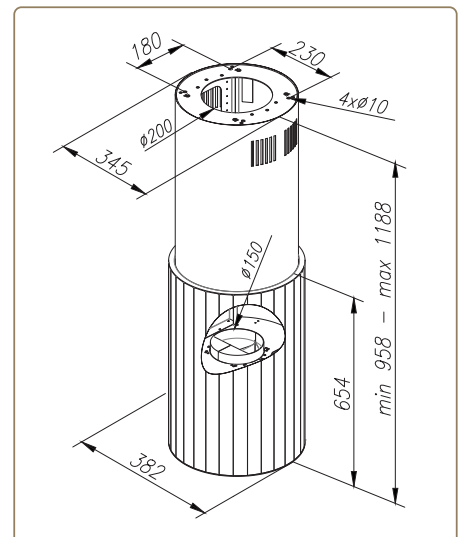

**ROTO W**

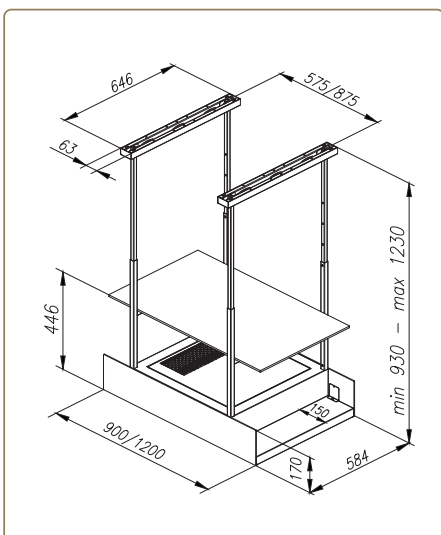

**MINIMAL 1 - 90 cm / 120 cm**

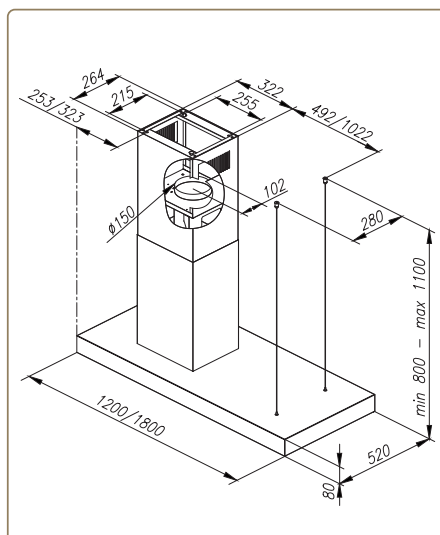

**MINIMAL 2 - 120 cm / 180 cm**

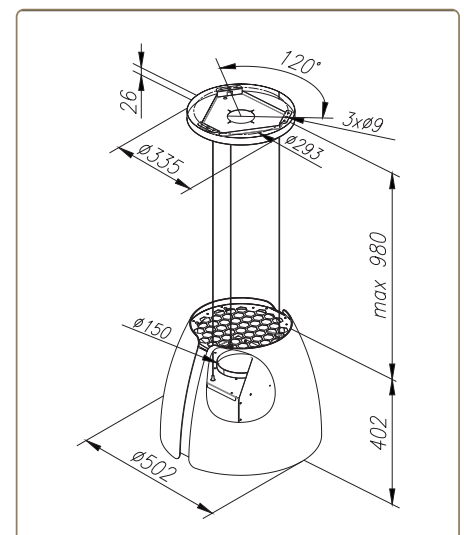

**MISS W**



# LAMP AND COOKER HOOD IN ONE

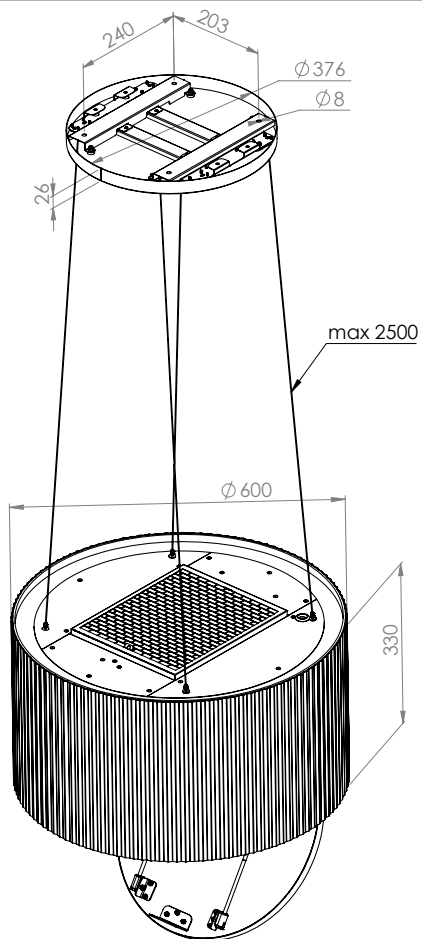

MONO LIGHT / 60 CM

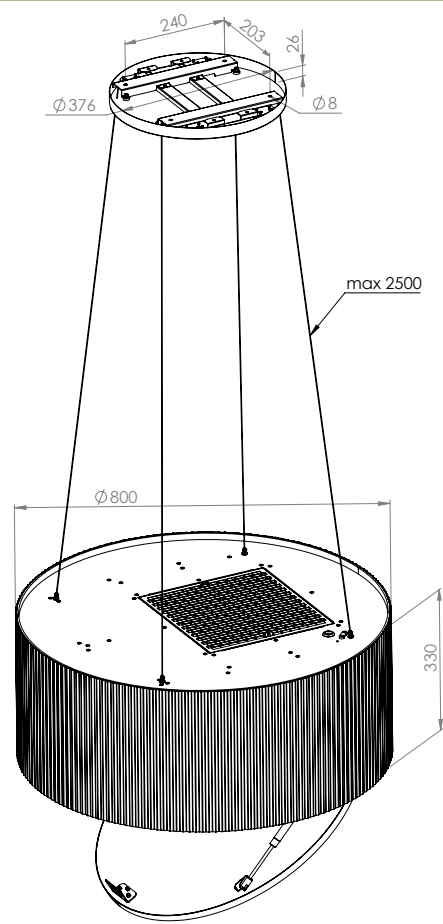

MONO LIGHT / 80 CM

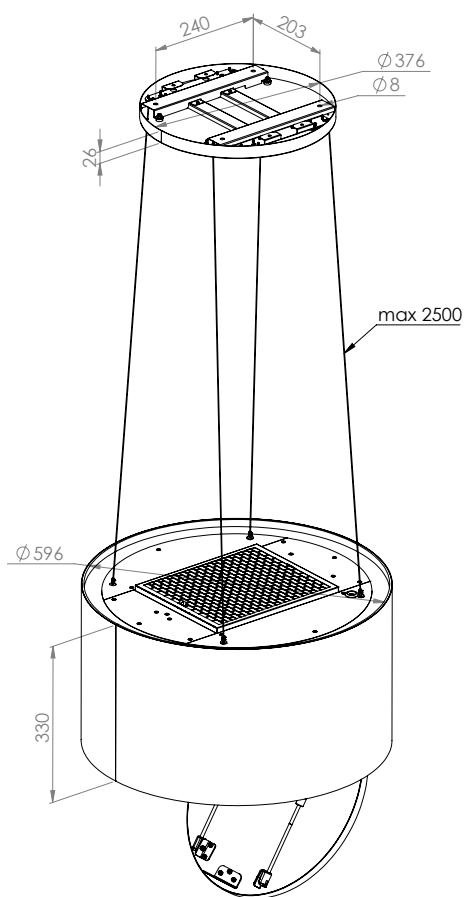

PIU LIGHT / 60 CM

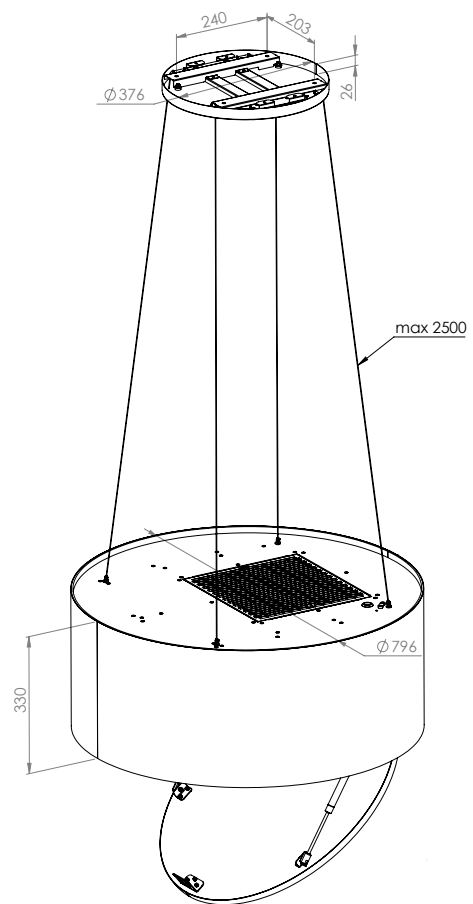

PIU LIGHT / 80 CM

# WALL HOODS

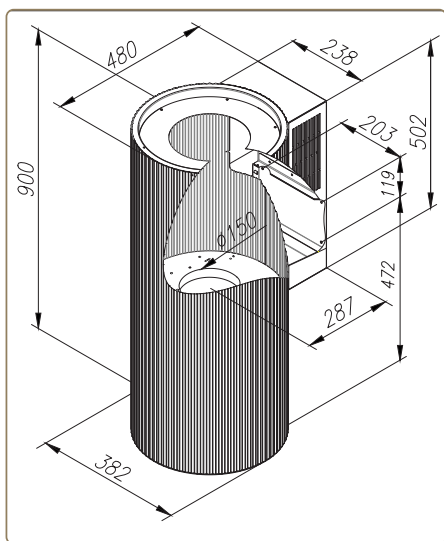

**MONOGRAM**

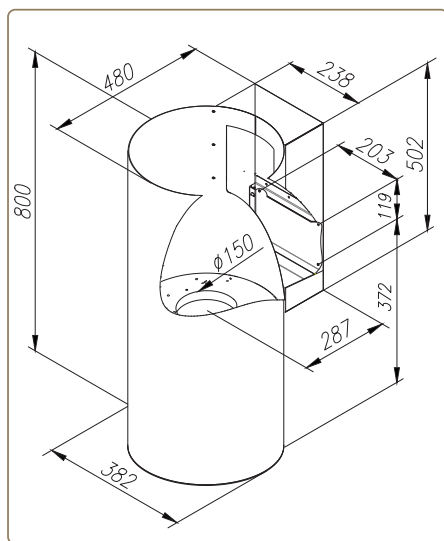

**TUBUS**

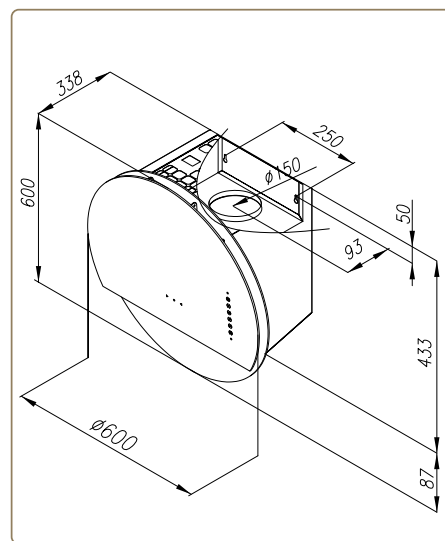

**ECLIPSE**

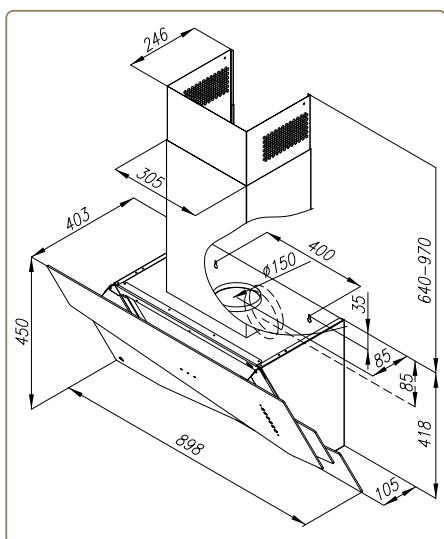

**TRIO**

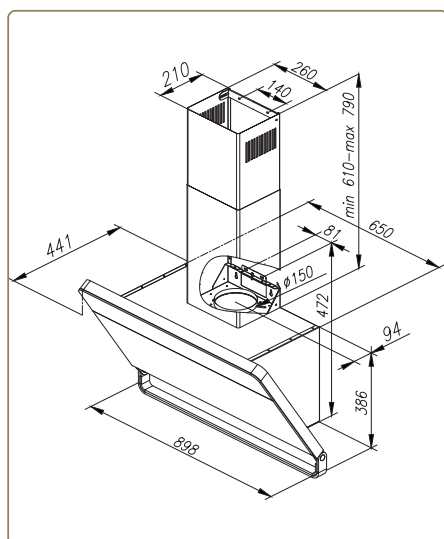

**ILLUMIA**

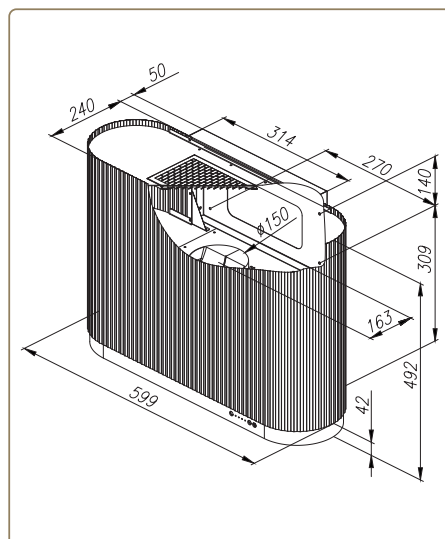

**MONO - 60 cm**

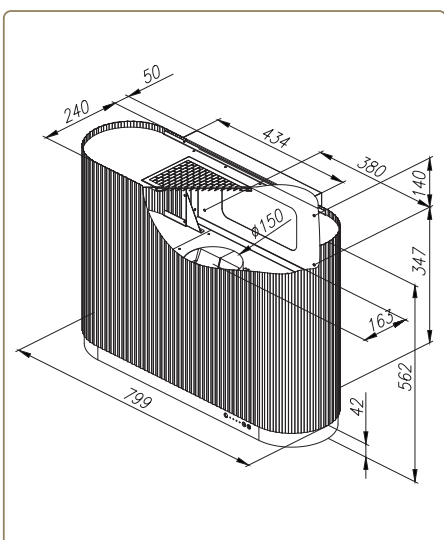

**MONO - 80 cm**

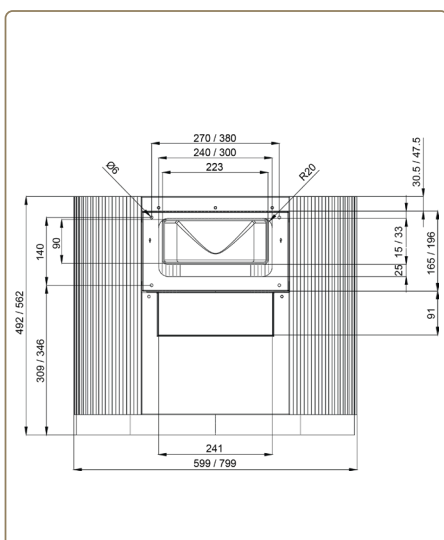

**MONO 60/80 - REAR**

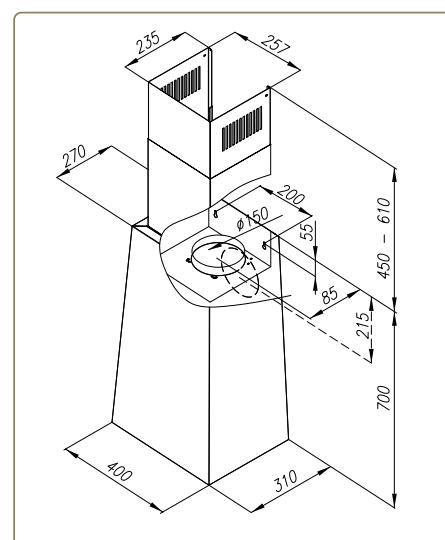

**MINIMAL 3**

# WALL HOODS

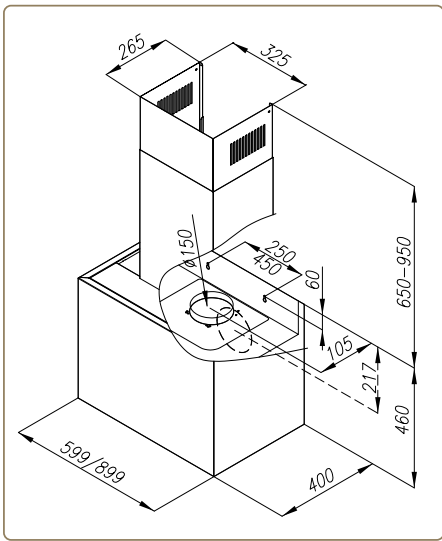

**MINIMAL 4 - 60 cm / 90 cm**

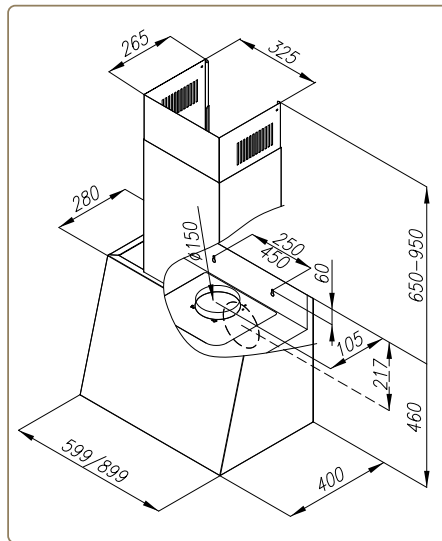

**MINIMAL 5 - 60 cm / 90 cm**

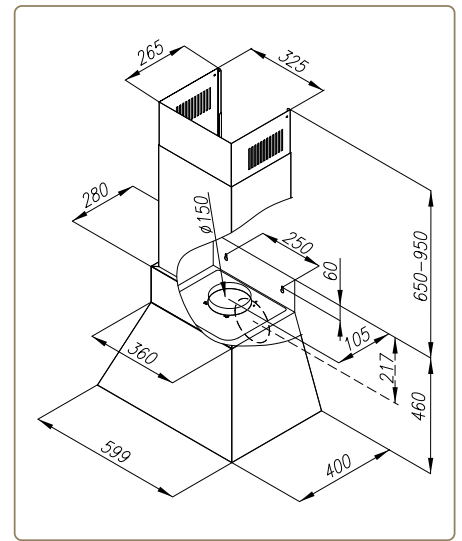

**MINIMAL 6 - 60 cm**

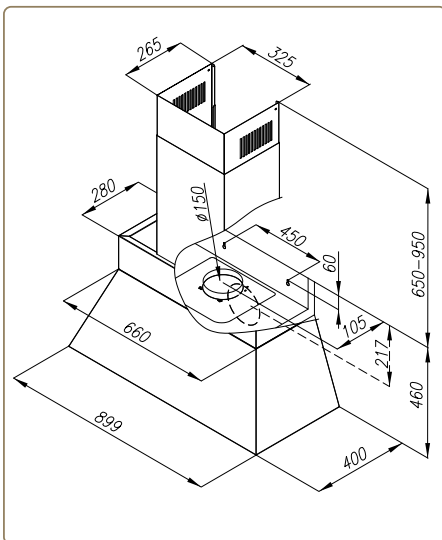

**MINIMAL 6 - 90 cm**

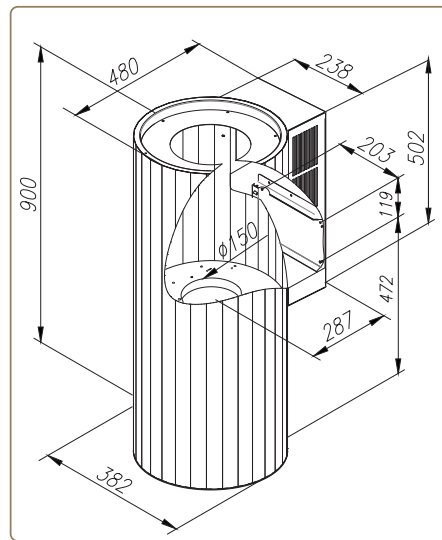

**ROTO**

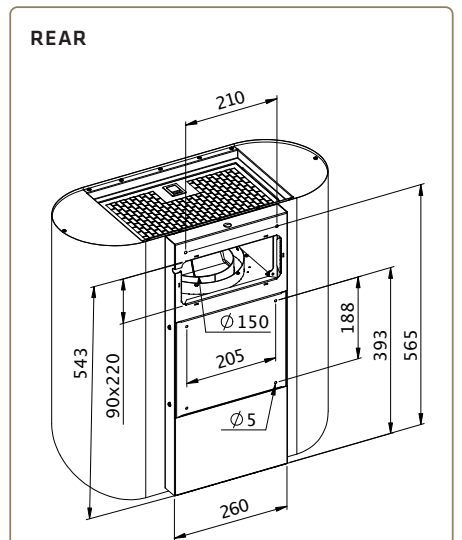

**REAR**

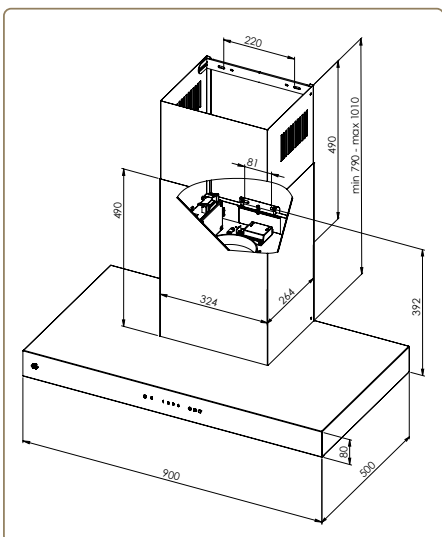

**MINIMAL 8**

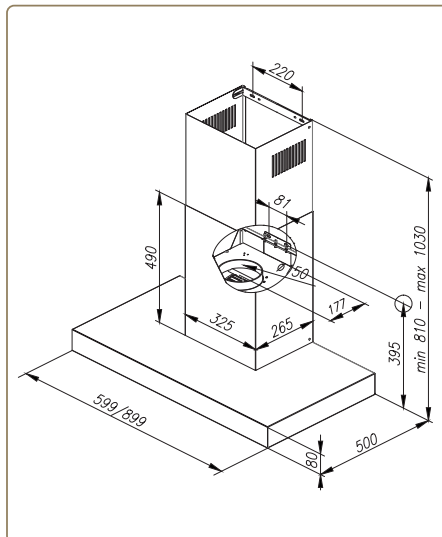

**T LIGHT - 60 cm / 90 cm**

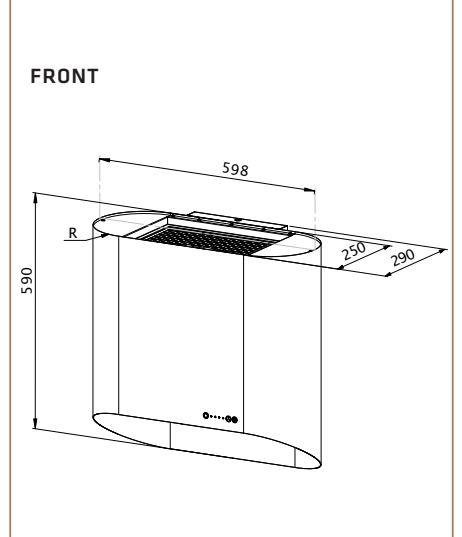

**FRONT**

**SIMPLE**

# UNDER-CABINET MODELS

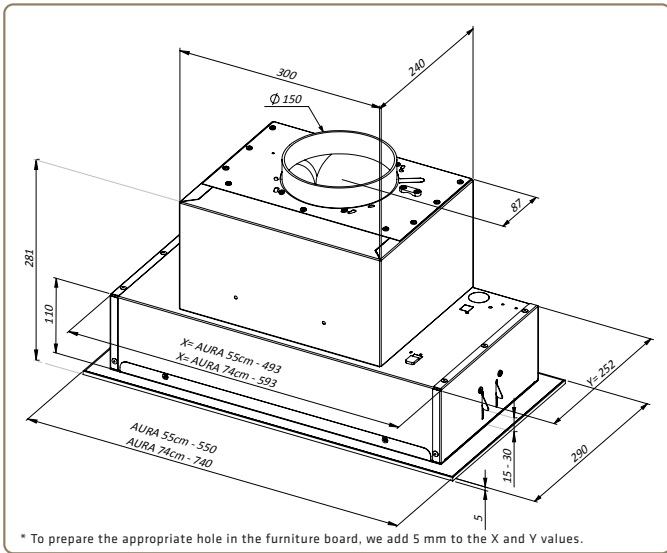

**AURA - 55 cm / 74 cm**

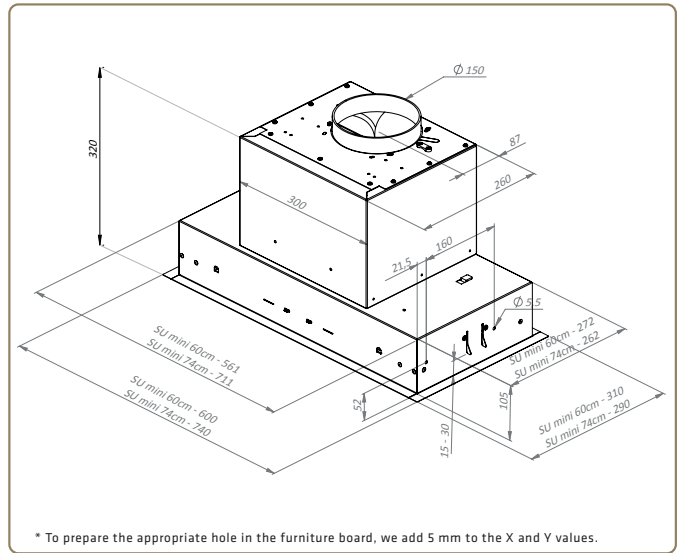

**SU MINI - 60 cm / 74 cm**

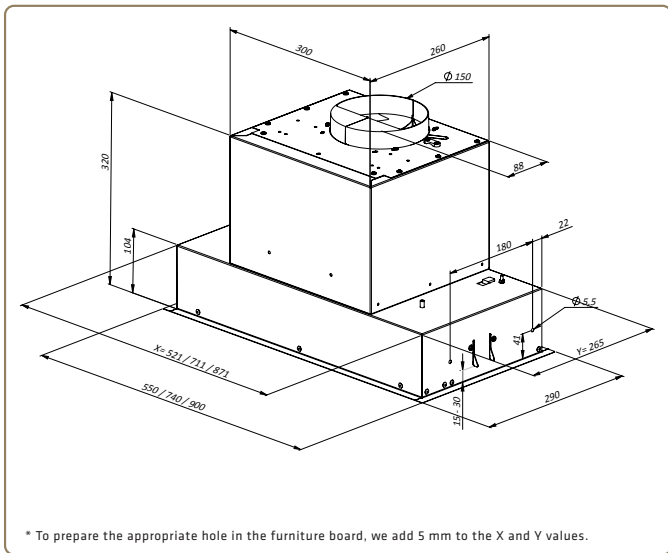

**MINIMAL 7 - 55 cm / 74 cm / 90 cm**

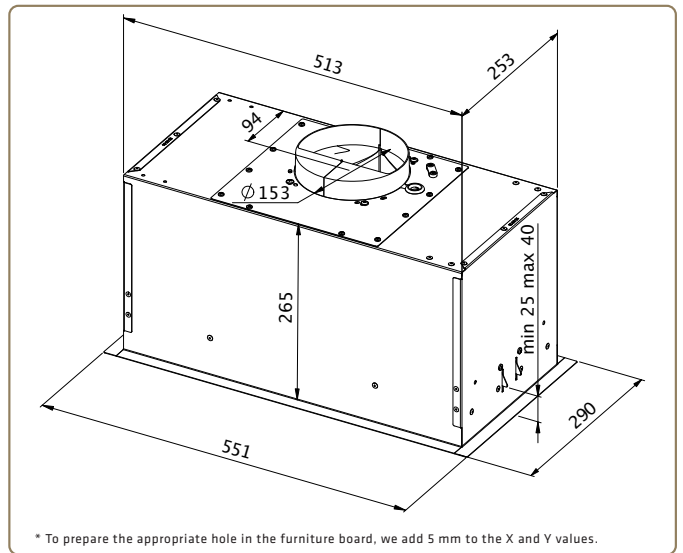

**UNO - 55 cm**

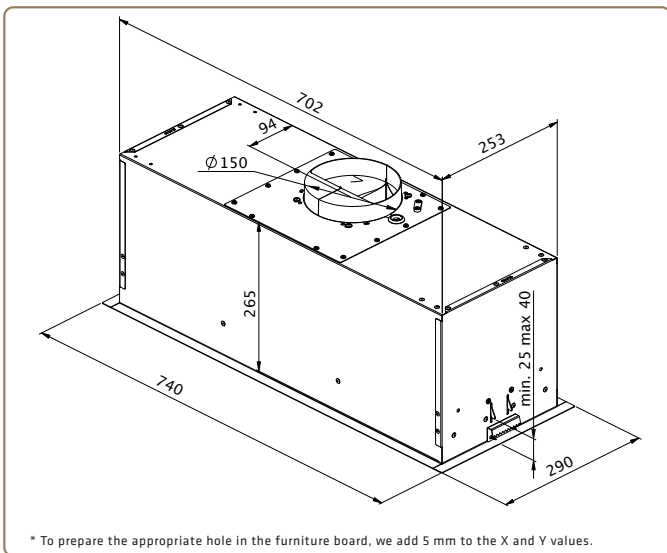

**UNO - 74 cm**

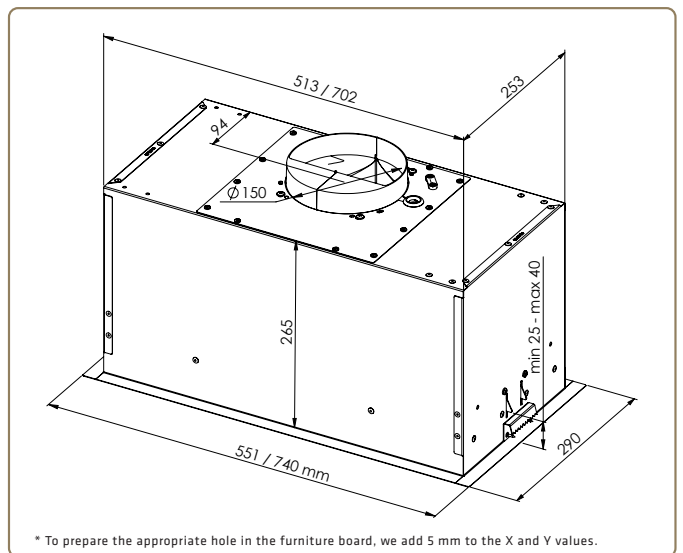

**DUO - 55 / 74 cm**

# ACCESORIES

## SPACEMAX JOKER

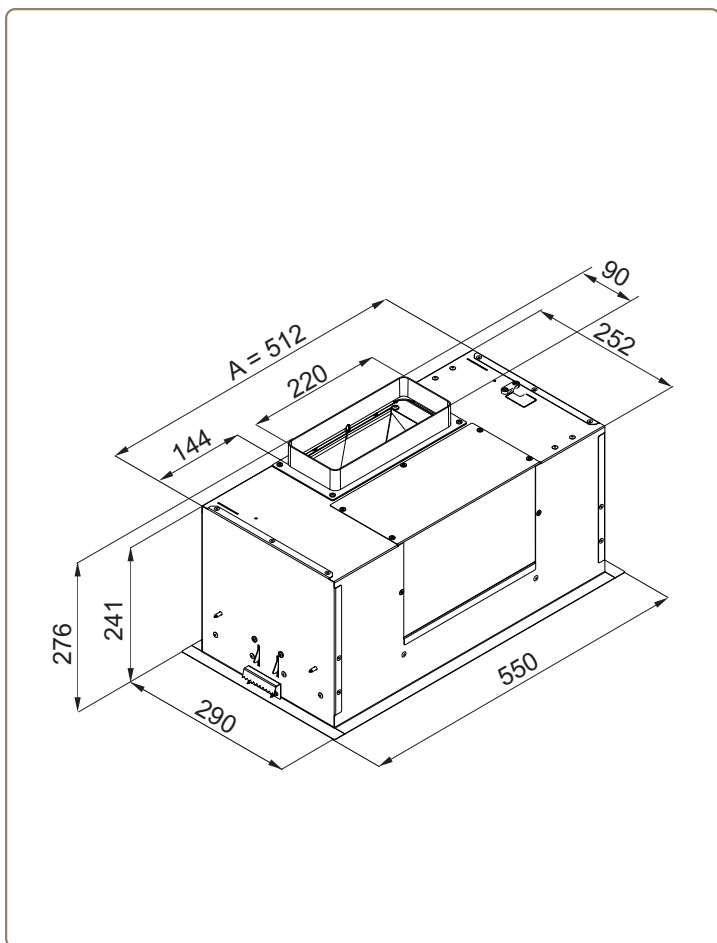

JOKER UNO / DUO 55 CM

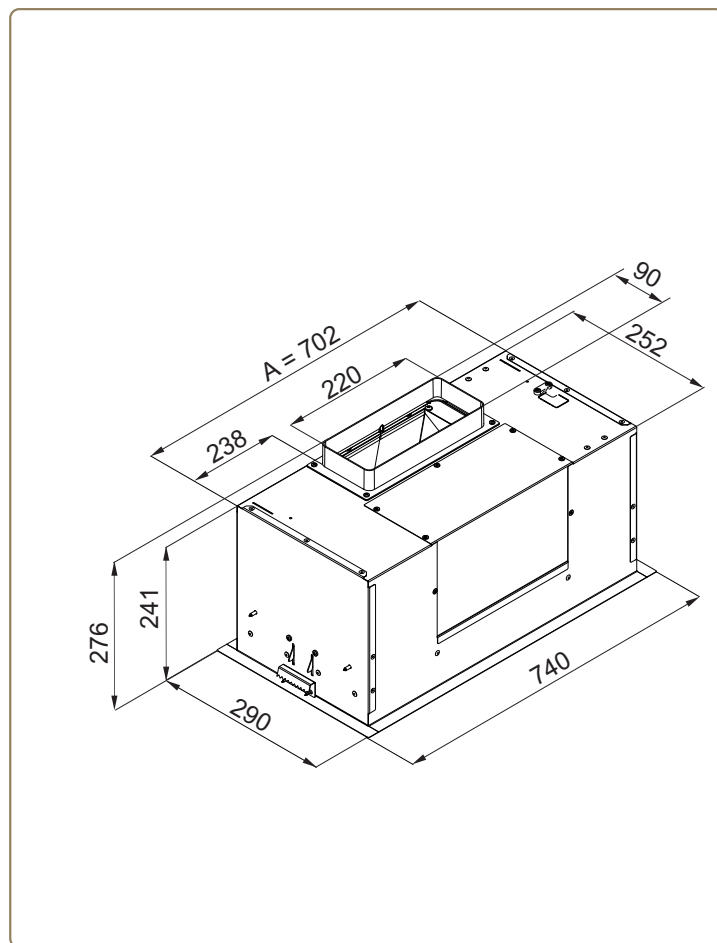

JOKER UNO / DUO 74 CM

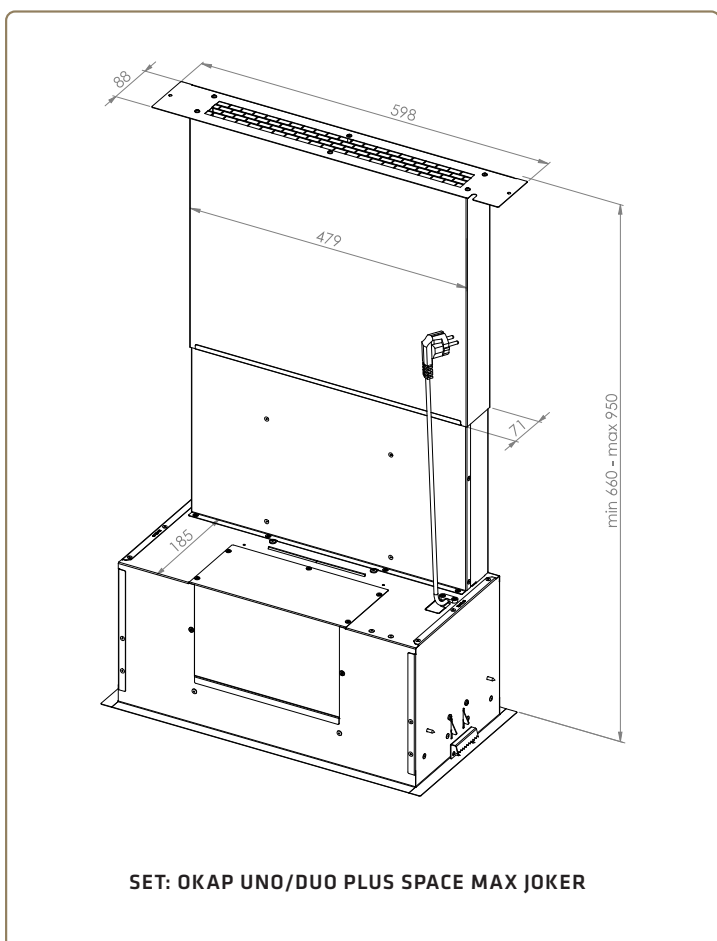

SET: OKAP UNO/DUO PLUS SPACE MAX JOKER

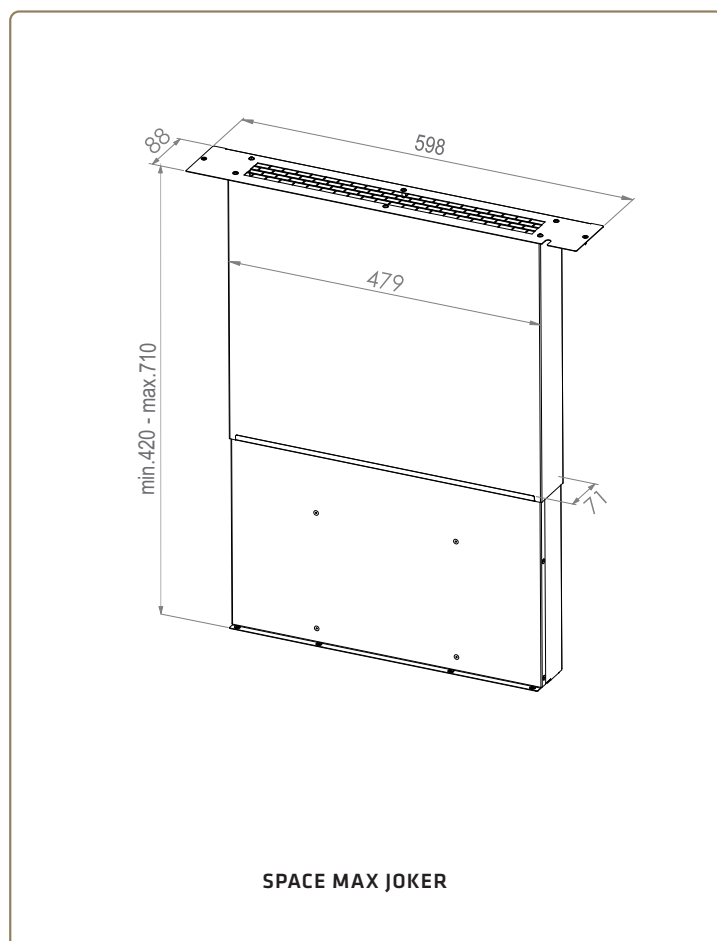

SPACE MAX JOKER

## CEILING MODELS

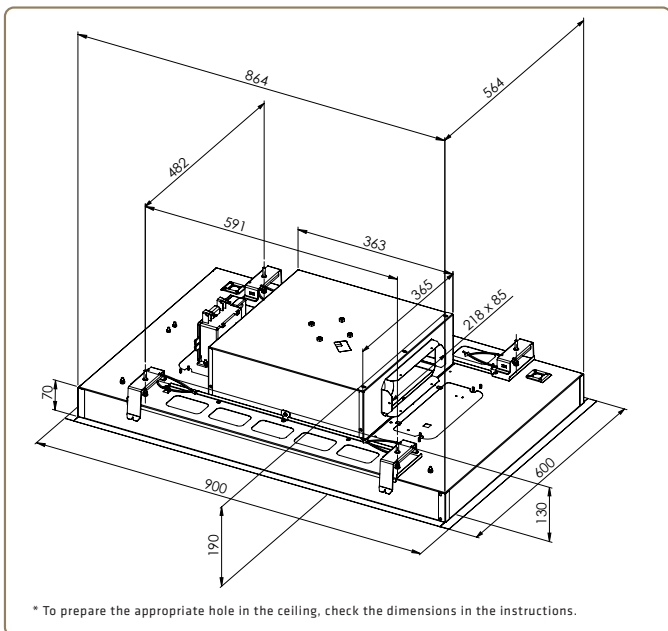

**SU FRAME / SU LIGHT**

## COUNTERTOP MODEL

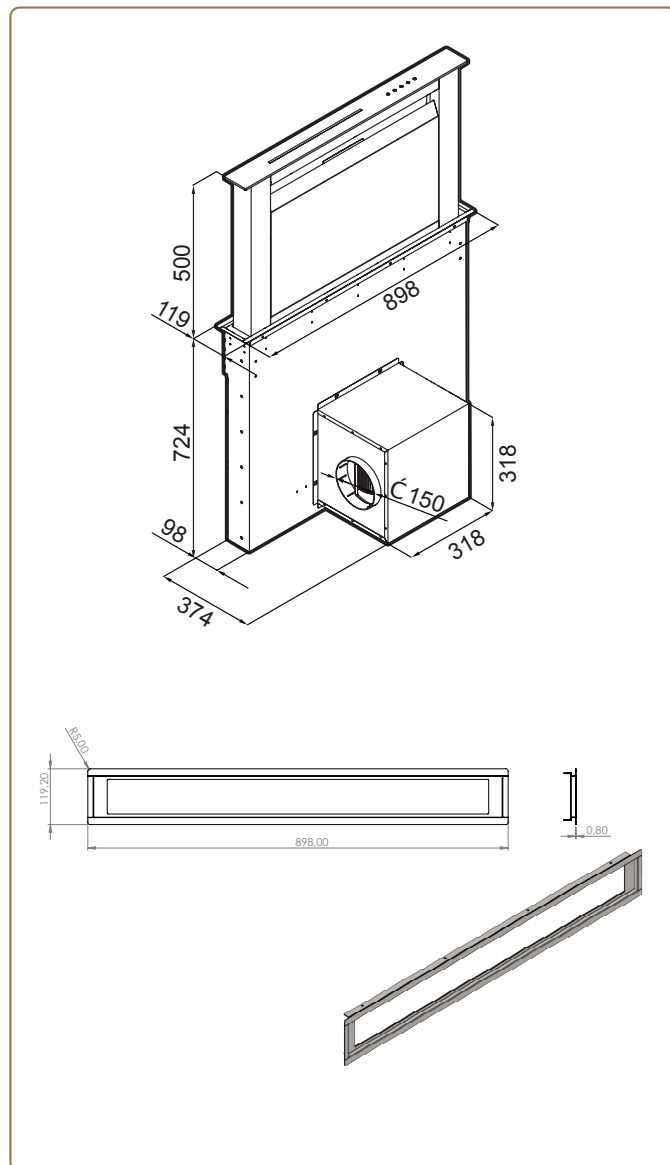

**MOONDRAFT / 90 CM**

## COUNTERTOP MODEL

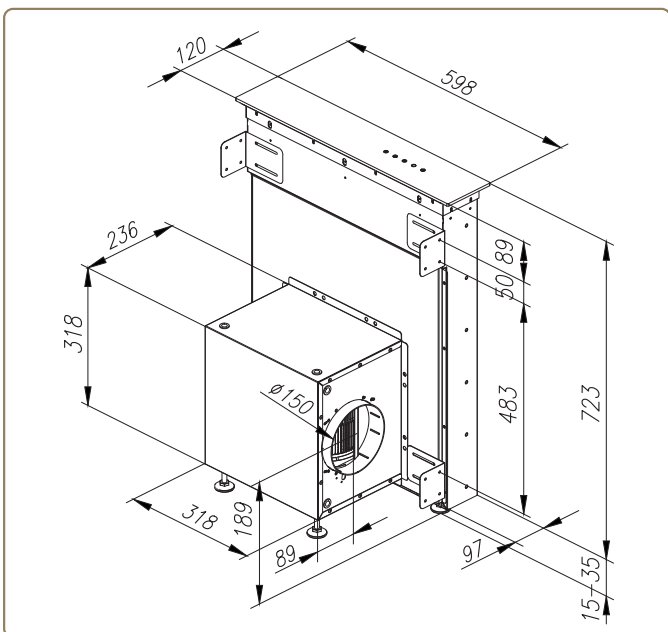

**MOONDRAFT / 60 CM**

# MODEL INTEGRATED WITH AN INDUCTION HOB

WIZARD 2.0

(OUTLET DOWN)

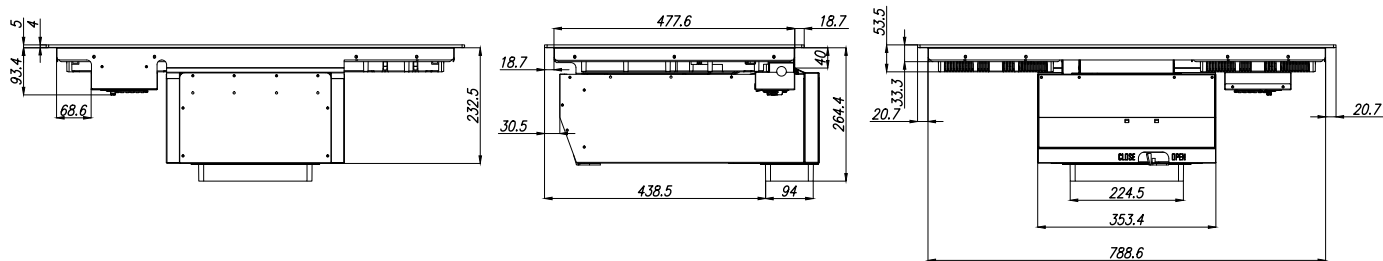

(REAR OUTLET)

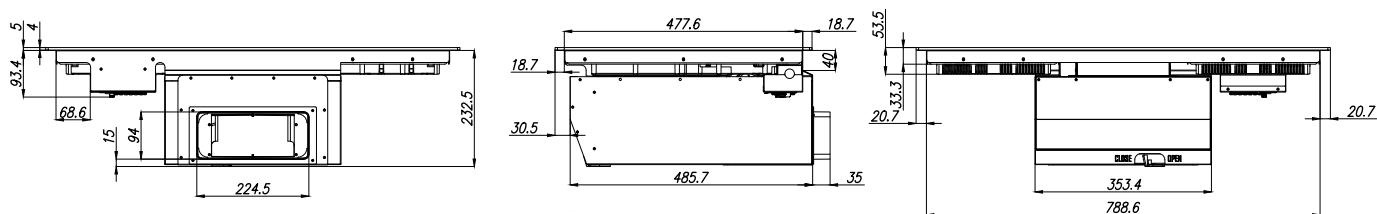

TO REMOVE AIR, USE A FLAT DUCT WITH DIMENSIONS OF 220X90 MM.

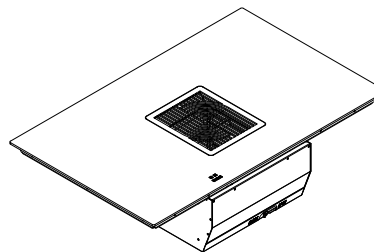
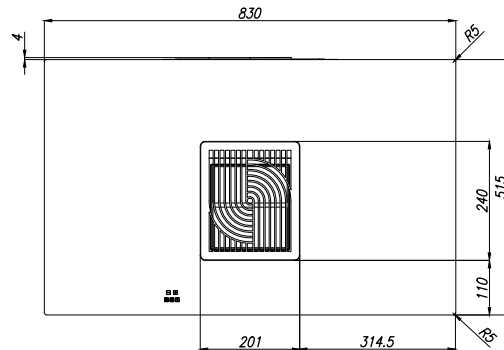
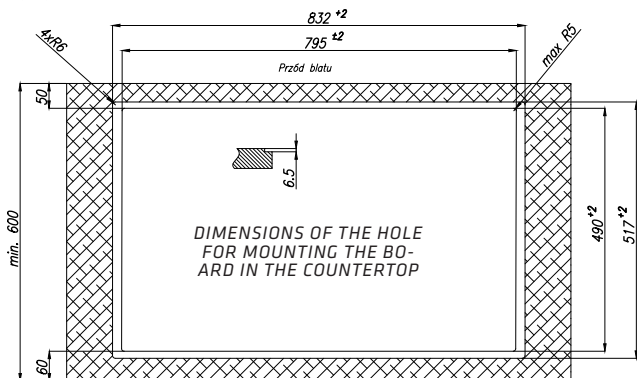
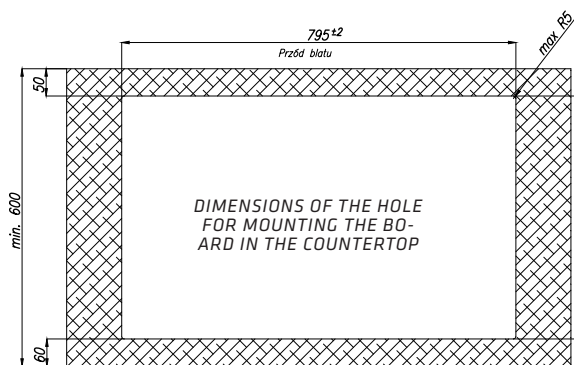

# MODEL INTEGRATED WITH AN INDUCTION HOB

WIZARD ONE

(OUTLET DOWN)

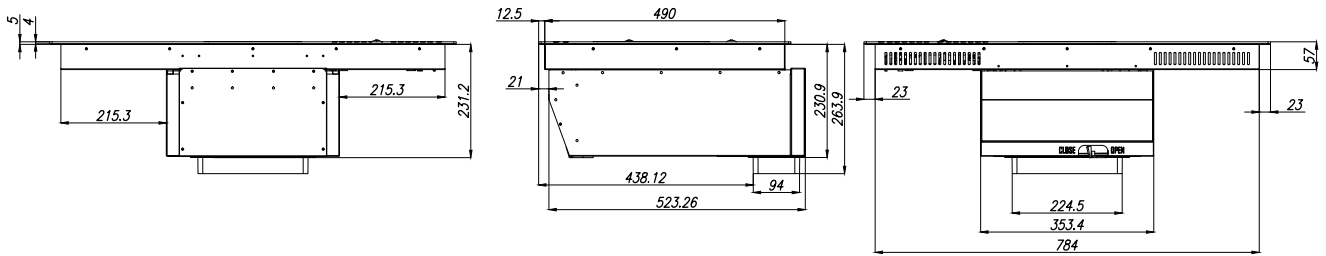

(REAR OUTLET)

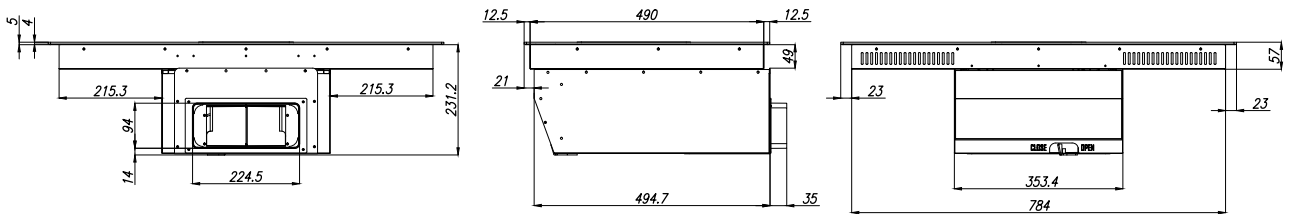

TO REMOVE AIR, USE A FLAT DUCT WITH DIMENSIONS OF 220X90 MM.

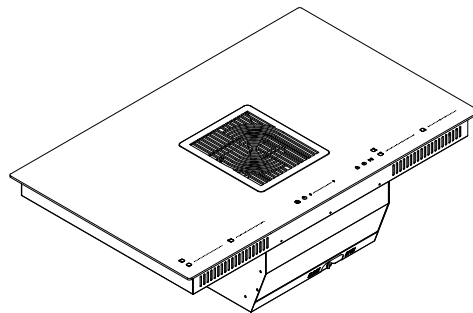
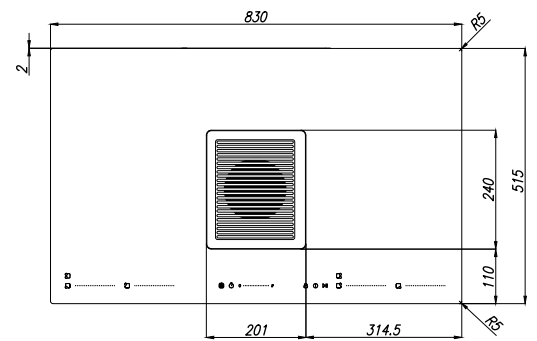
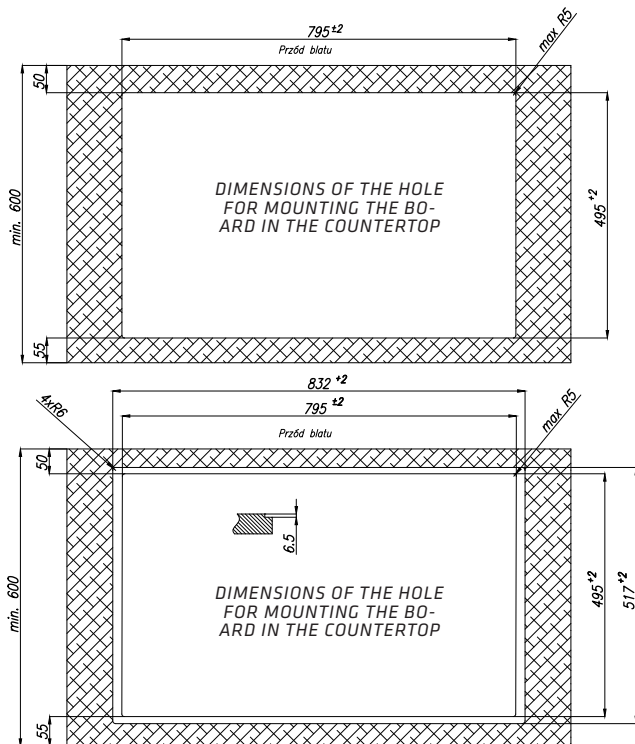



# MODEL INTEGRATED WITH AN INDUCTION HOB

WIZARD SLIM

(OUTLET DOWN)

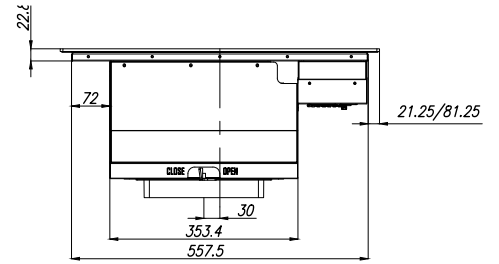
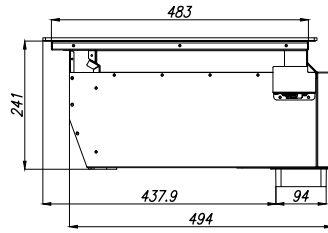
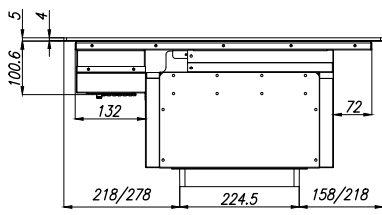

(REAR OUTLET)

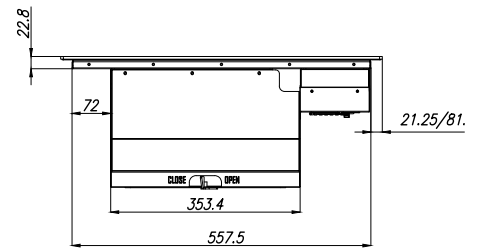
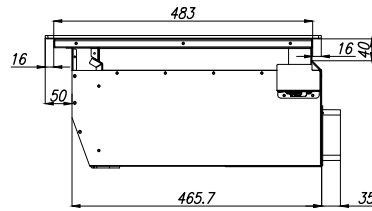
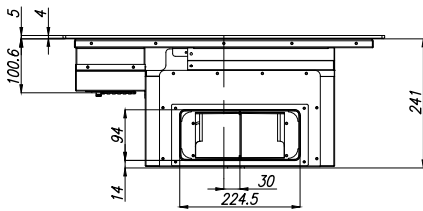

TO REMOVE AIR, USE A FLAT DUCT WITH DIMENSIONS OF 220X90 MM.

600/720

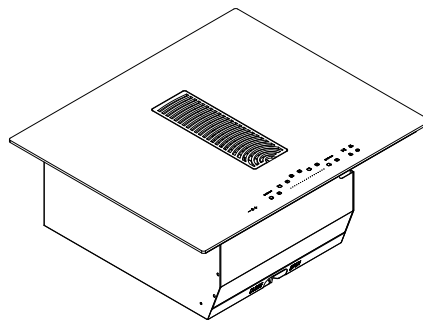
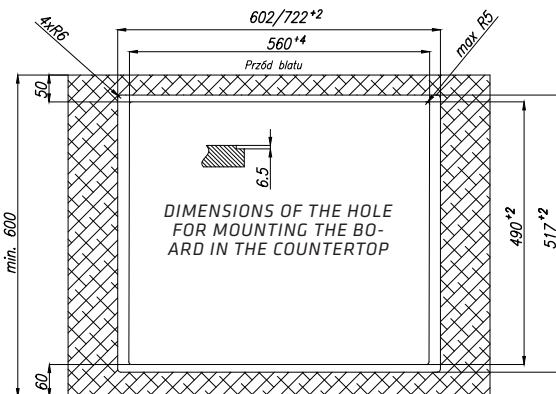
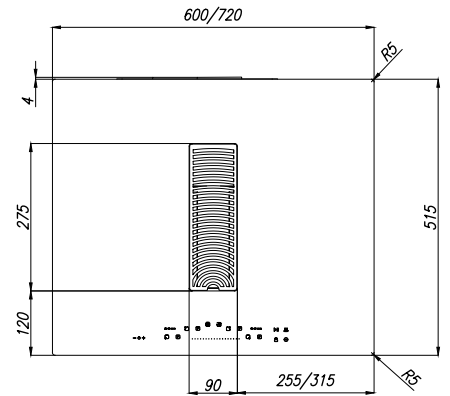
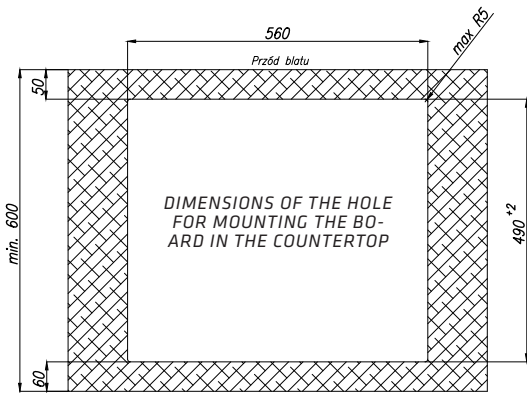

**ACCESSORIES**  
SPACEMAX WIZARD

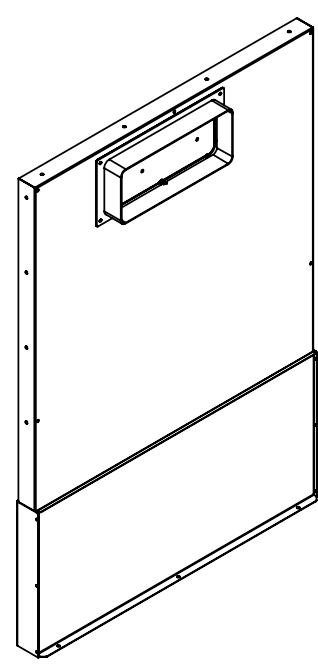
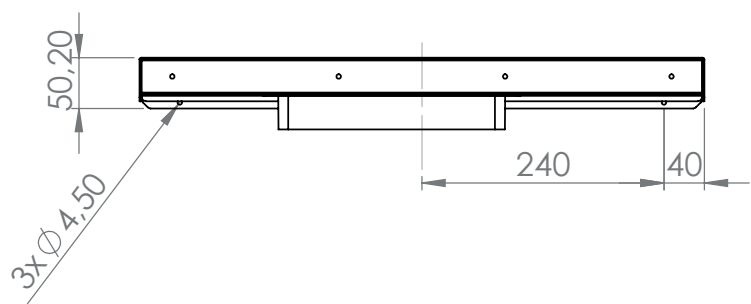
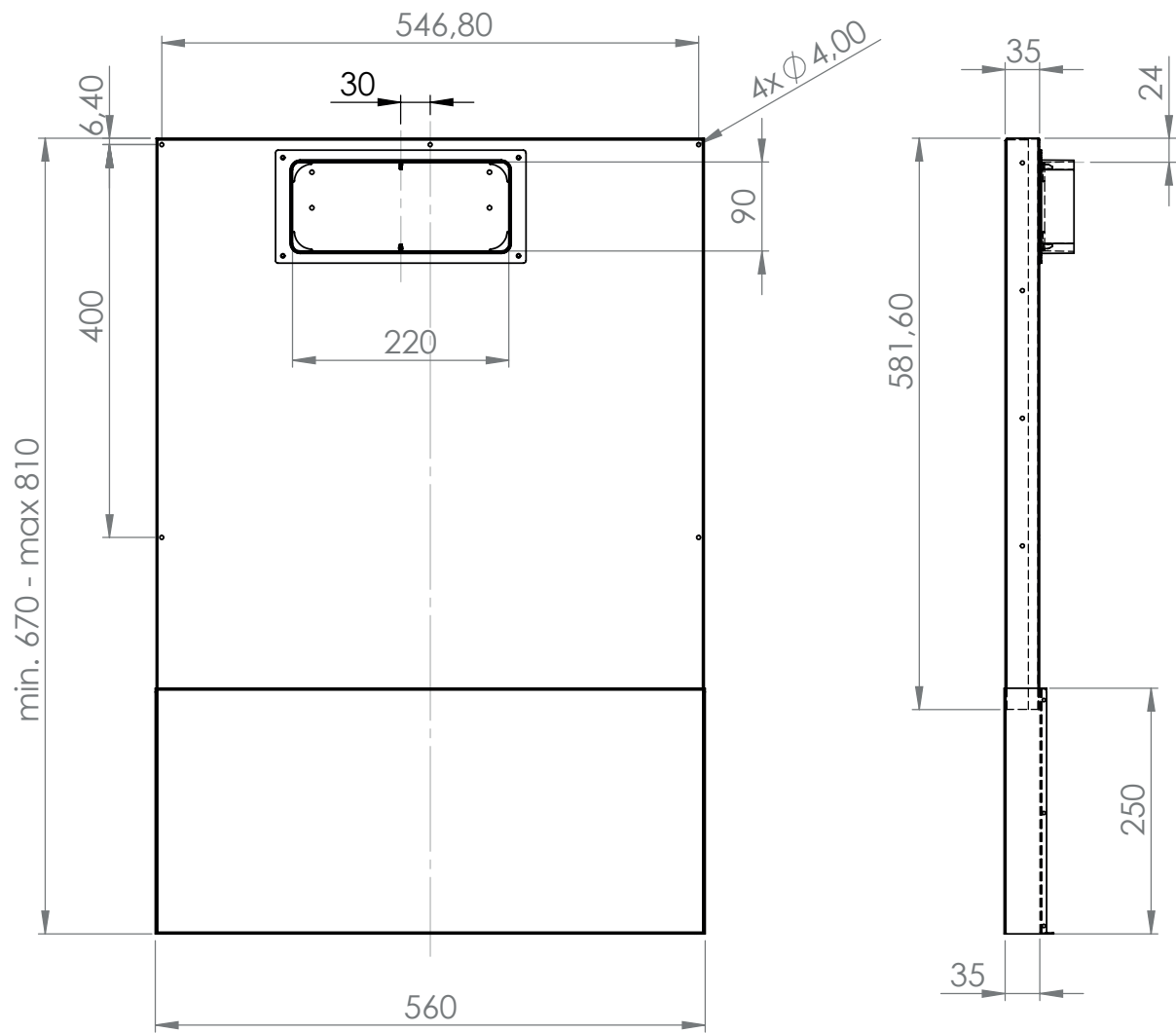

# INDUCTION HOBS

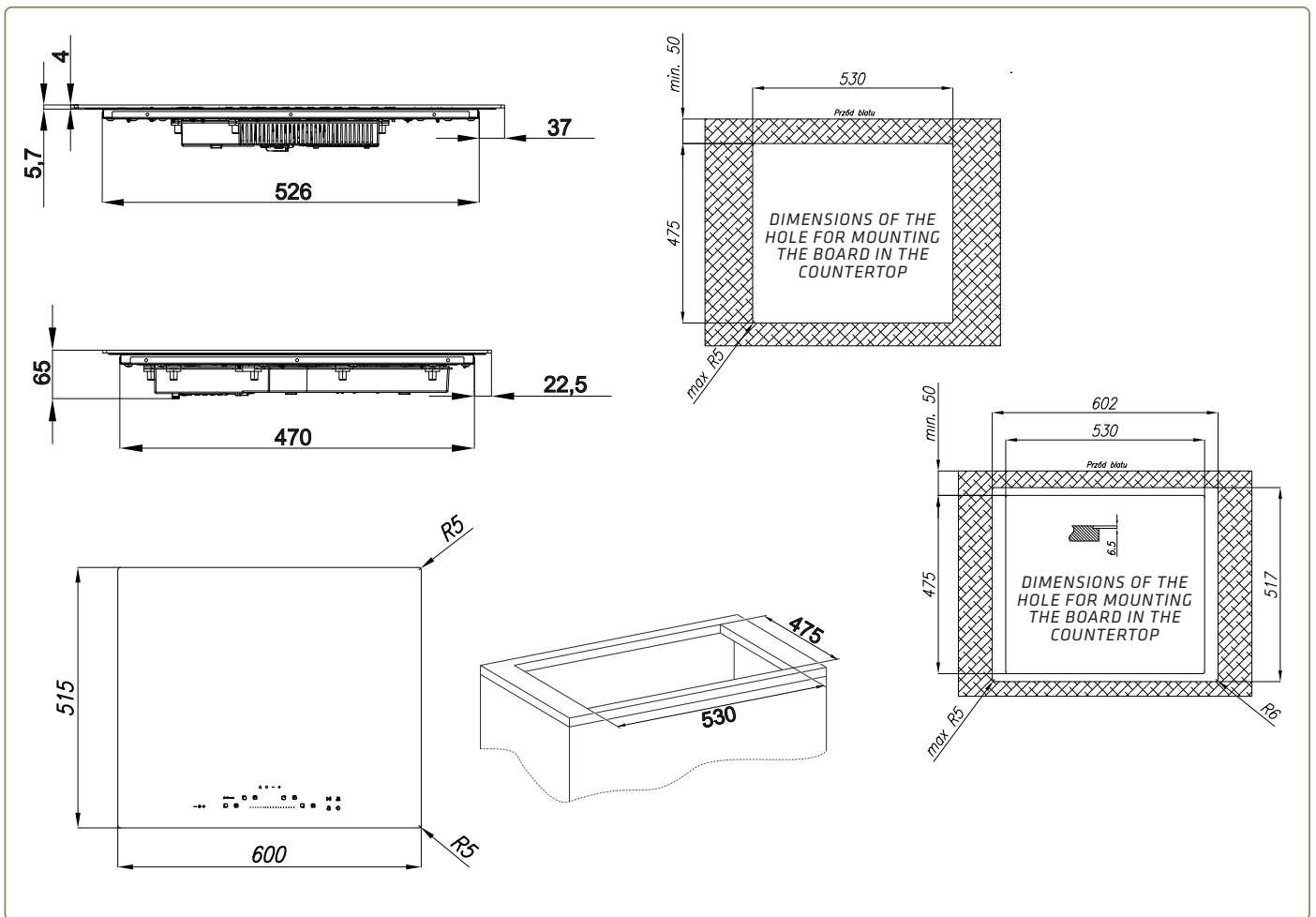

## CULINASYNC ADVANCED

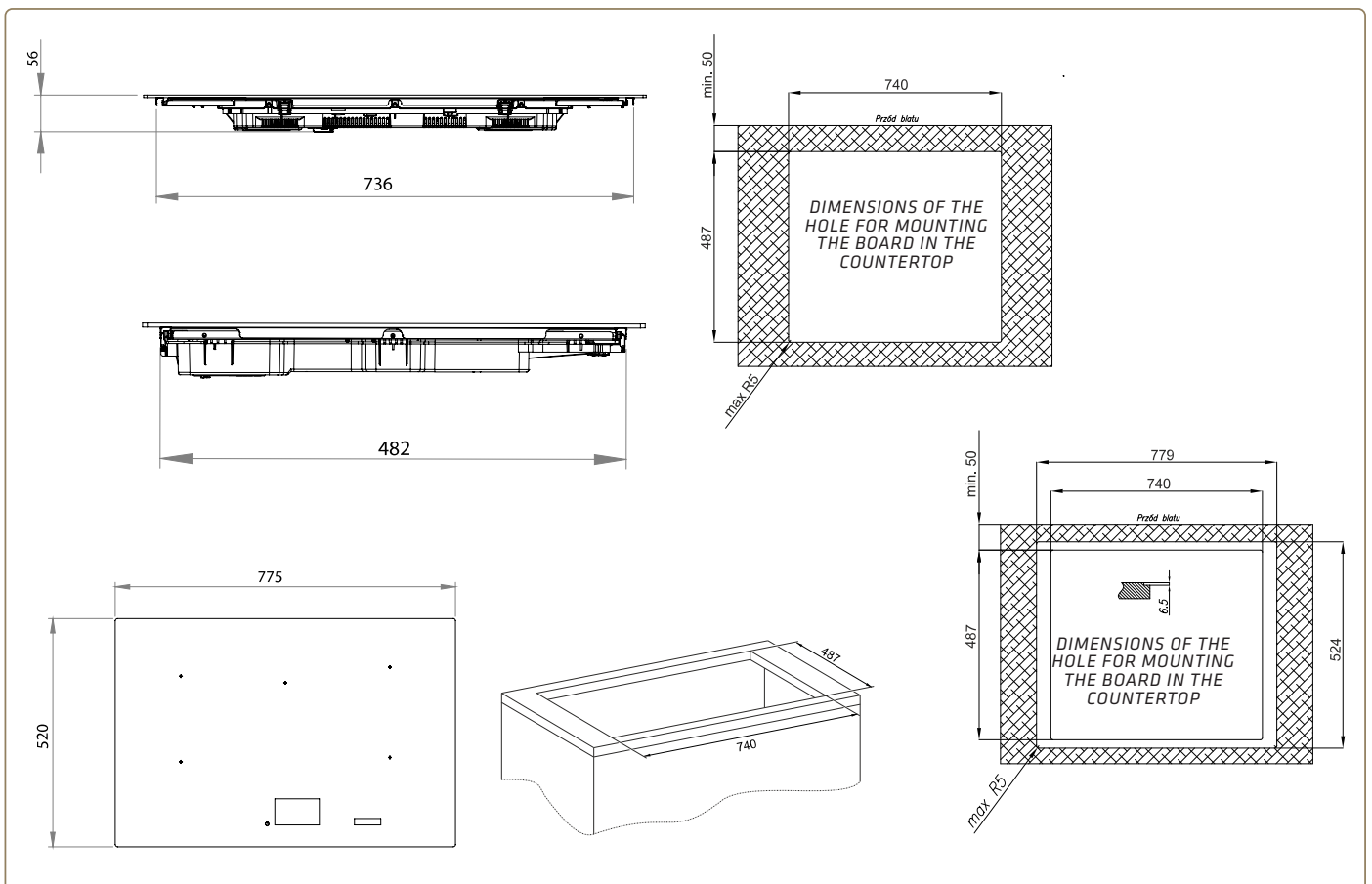

## CULINASYNC ULTIMATE



 **CIARKO**<sup>®</sup>  
DESIGN